



User manual

ACOWA SPIDER / AcowaZoo

072020



ACOWA
INSTRUMENTS

Table of Content

Content

| | |
|---|-----------|
| SPIDER | 4 |
| About SPIDER..... | 4 |
| Funktionen | 4 |
| Installation..... | 5 |
| Power supply | 5 |
| Psychical specifications..... | 5 |
| Installation environments..... | 5 |
| Build-in power supply..... | 5 |
| Analog input | 6 |
| Digital input with the option of 0-10V analog | 6 |
| Digital output..... | 6 |
| Operation | 7 |
| Overview..... | 7 |
| The red button..... | 7 |
| SPIDER diodes..... | 8 |
| External unites..... | 8 |
| I/O module..... | 8 |
| Installation..... | 8 |
| Communication via ModBus | 9 |
| Installation instructions..... | 9 |
| Displays | 10 |
| Display 2,4" OLED | 10 |
| Installation instructions | 10 |
| Menu structure for the 2,4" OLED Display | 10 |
| Display EAGLE HMI 7" | 11 |
| Installation guide | 11 |
| Menu structure for 7" EAGLE HMI Display | 11 |
| AcowaZoo..... | 18 |
| Connecting to a PC | 18 |
| USB connection | 18 |
| TCP Connection | 18 |
| AcowaZoo Installation | 18 |

| | |
|---|-----------|
| Driver installation | 18 |
| Program installation | 18 |
| Setup | 20 |
| AcowaZoo user interface..... | 20 |
| Overview..... | 20 |
| Function buttons | 20 |
| Function menu..... | 22 |
| Settings selection..... | 24 |
| SPIDER details..... | 24 |
| Input and output Settings..... | 25 |
| Analog Input (AI1)..... | 25 |
| Digitale Input (I1–I6)..... | 26 |
| Digital output..... | 30 |
| Contact device via TCP/IP..... | 33 |
| Device settings / advanced settings | 34 |
| Reports and alarms:..... | 34 |
| Reverse Comm:..... | 34 |
| Show Status | 37 |
| Online status..... | 37 |
| Graphical and schematic view | 38 |
| Applications | 39 |
| Pump control:..... | 39 |
| Flow interface:..... | 39 |
| Additional Options:..... | 40 |
| Groundwater lowering: | 40 |
| Monitoring:..... | 41 |
| Compressor control: | 41 |
| Concertor control: | 41 |
| Other functions..... | 43 |
| High level switch version 2 (advanced function):..... | 43 |
| SPIDER pump control using only level switch:..... | 44 |
| Register list "quick-guide" | 49 |
| Analog..... | 49 |
| Input | 49 |
| Output | 49 |
| Pump control | 49 |
| External gauges..... | 50 |
| Converters | 50 |
| Pump word | 50 |
| Time / Date..... | 51 |
| SPIDER status: Register 92..... | 51 |

SPIDER

About SPIDER

SPIDER is a universal control with functions for pump control, data collection, alarm management, groundwater lowering etc.

SPIDER is developed and produced in Denmark. SPIDER complies with all specifications regarding placement of electronic components in harsh environments.

Funktionen

- Advanced 1 and 2 pump control with empty/fill function and internal pump alternation.
- Build-in GSM/GPRS Modem.
- Multiprotocol, Modbus RTU/TCP & COMLI. SPIDER auto-detects the protocol used by the SCADA system.
- Click connection for a joystick-equipped graphic 2,4" OLED display directly onto SPIDER.
- Possibility to connect a 7" color touch-sensitive display via a serial HMI interface.
- Validated flow calculation where the pump's exact capacity is calculated.
- Status words function that can take a failed pump out of operation.
- Emergency control function via a float switch when a pressure transmitter fails.
- Indication of required pump service where SPIDER informs that a pump has reduced capacity.
- Built-in power bank that maintains control during power failures and sends an alarm to SCADA.
- Daily running of pumps so they do not seize after long idle periods.
- Daily depth pumping to avoid top sediment layer.
- Choice of various start levels to prevent sediment accumulation at liquid entrance point.
- Configuration of SPIDER via ACOWA ZOO software, both locally (Micro USB cable) or via server setup.

Installation

Power supply

SPIDER must be connected to a supply voltage according to the specifications below.

| | |
|---------------------------|---------------------|
| Voltage supply | 230 VAC +10% / -20% |
| Frequency | 50/60Hz |
| Input current consumption | 0,004 -> 0,06A |
| Startup current | <10A |
| Own consumption | Maximum of 10W |
| Fuse | ≤250mAT |



SPIDER is equipped with a built-in Power bank and can send voltage failure alarms when the primary power supply disappears.

The SPIDER Power bank (the two green high capacity capacitors) is located on the bottom of the top print.

WARNING! Do not disassemble device until Power bank is turned off.

Psychical specifications

For the installation of the SPIDER controller, the following specifications may be required.

SPIDER can be mounted on a standard 35mm DIN-rail.

| | |
|---------------------------|--------------------------------|
| Dimensions | L = 87mm x H = 90mm x W = 62mm |
| Weight | 250g |
| Cable connection | 0.5 – 2,5 mm ² |
| Vibrations (sinus shaped) | 10-500Hz, 1G |

Installation environments

SPIDER must not be installed in direct sunlight

| | |
|-----------------------------|---|
| Humidity | 10% - 95% non-condensing |
| Operation temperature | -20°C til +50°C |
| Storage temperature | -20°C til +60°C |
| Maximum operation elevation | Maximum of 2000m above sea level |
| Free fall drop | 30cm |
| Enclosure class | IP20 |
| Start-up time total | 20-120 secs. (depending on the GSM network) |

Build-in power supply

SPIDER has an internal power supply designed for supplying sensors and input and output signals. Power supply output + V:

| | |
|----------------|------------|
| Output voltage | 24 V DC |
| Output current | Max. 100mA |
| Tolerance | + / - 20% |

Analog input

SPIDER is designed with one analog input 0-20mA / 4-20mA.

| | |
|-----------------------------|----------------------|
| Numbers of analog mA inputs | 1 |
| Electrically isolated | No |
| Measuring range | 0 / 4 – 20mA |
| Input impedance | Approx. 100 Ω |
| Measuring accuracy | +/- 1% of FS |
| Signal area | 0-24mA / 0 – 30 V DC |
| Signal frequency | Maximum of 100 Hz |
| Cable / signal length | Maximum of 100m |

Digital input with the option of 0-10V analog

SPIDER has 6 digital inputs, all of which can be selected as 0-10V analog voltage inputs.

| | |
|---------------------------|--|
| Numbers of digital inputs | 6 |
| Electrically isolated | No |
| Digital signal | Low < 5 V / < 1 mA High > 12 V / > 4 mA |
| Analog measuring range | 0 – 10 V DC |
| Analog signal impedance | Approx. 20KΩ |
| Measuring accuracy | +/- 1% of FS |
| Signal range (min / max) | 0 – 30 V DC |
| Signal frequency | Maximum of 100 Hz |
| Cable / signal length | Maximum of 100m |

Digital output

SPIDER is equipped with 4 digital relay outputs.

| | |
|----------------------------|--|
| Numbers of digital outputs | 4 |
| Electrically isolated | Yes |
| Insulation voltage | 4 KV |
| Relay type | Relay output |
| Kabel / signal length | Maximum of 100m |
| Relay NO #11 and #21 | |
| Constant load | Maximum of 10 A @ 230Vac - AC1 Maximum of 500 W @ 230Vac - AC3 Maximum of 1 A @ 48 VDC Maximum of 10 A @ 24 VDC |
| Minimum current | 5 mA @ 10 V |
| Max. Start-up current | 18A |
| Switch speed | Maximum of 1 Hz |
| Relay NO #31 and #41 | |
| Constant load | Maximum of 2 A @ 230Vac - AC1 Maximum of 100 W @ 230Vac - AC3 Maximum of 1 A @ 30 VDC |
| Minimum current | 5 mA @ 10 V |
| Max. Start-up current | 6A eller 10A @ 20 mS |
| Switch speed | Maximum of 10 Hz |

Operation

Overview

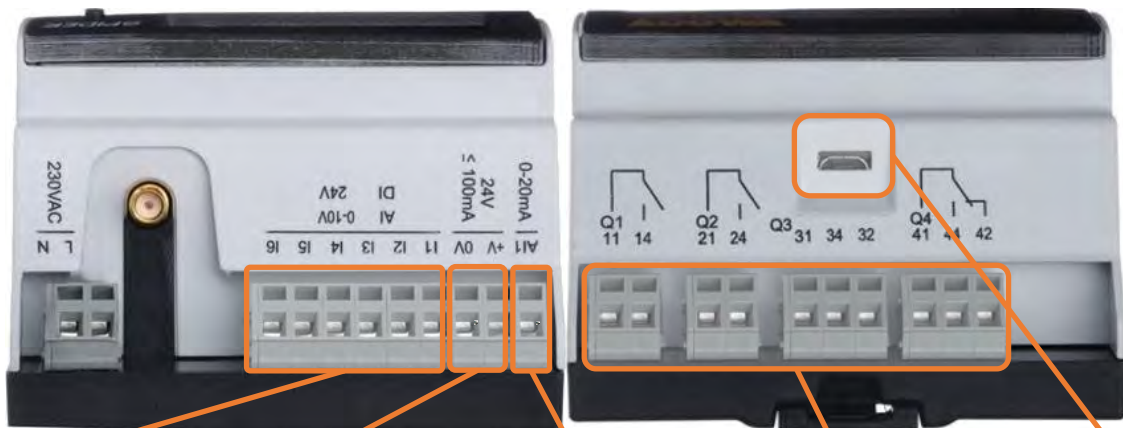

- Digital Inputs
- Power supply
- Analog inputs
- Digital outputs
- USB connection

The red button

SPIDER has a red button on the print next to the SIM card where it is possible to restart / reset SPIDER.

The red button on the top print has the following functions:



| The number of activations within a 5 sec. range. | Function |
|--|--|
| 1 | Reset modem |
| 3 | Enable / disable display interface (baud rate 57600 bps) |
| 5 | Enable HMI interface (baud rate to 38400 bps) |
| Hold the button in for 10 sec. | SPIDER restarts. Used in connection with fw-update or similar. |

SPIDER diodes

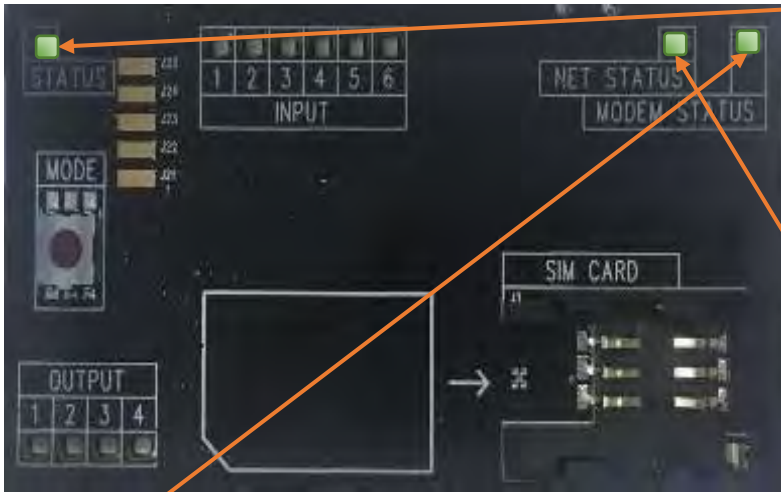

Status

Flashes every 5 seconds: status to indicate that the device is working.

Double flash means that the HMI interface / Oled display is enabled.

Net-status

Flashing fast (2 times per second) modem is not connected to the GSM mast.

Flashes slowly (once per second) and is connected to the GSM mast.

Modem-status flashes when a modem is connected to the GSM mast and a signal strength is detected.

External unites

I/O module

For connections of more signals, it is possible to connect an I/O module with multiple digital- and analog inputs.

The module allows for a total of 10 digital inputs and a further 2 analog 0-10 V DC inputs.

For setting up the extra inputs go to page 24.

Installation.

For correct installation, the I/O module must be connected to the SPIDER control the following way.

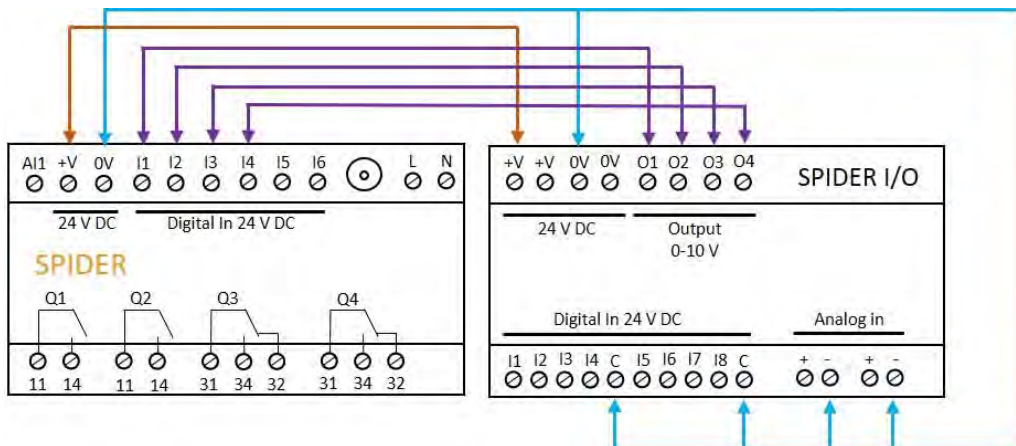

Communication via ModBus

The SPIDER can, via the ModBus-RTU protocol, communicate with several types of external devices. The SPIDER always writes the values in the same register for the same type of equipment, regardless of the brand of the device being communicated with (page 35). To communicate via ModBus, a serial interface module for the SPIDER is required.

Installation instructions.

For correct installation, remove the transparent front cover on the SPIDER. The interface module is then clicked on, so that the RJ45 socket is located to the right. The interface module comes with 1.5 meters of cable for RS485 connection between HMI and ModBus modules.



| | | |
|------------------------------------|---------------|--------------|
| SPIDER INTERFACE MODUL | ID 1 | |
| Pin 4 | Blue | |
| Pin 5 | White | |
| Pin 8 | Brown | |
| EAGLE HMI | MASTER | |
| Pin 1 | Blue | |
| Pin 6 | White | |
| Pin 5 | Brown | |
| DANFOSS FC 202 | ID100 | ID101 |
| Terminal 69 | Blue | |
| Terminal 68 | White | |
| Terminal 61 | Brown | |
| SCHNEIDER ALTIVAR | ID100 | ID101 |
| Terminal 5 | Blue | |
| Terminal 4 | White | |
| Terminal 8 | Brown | |
| ABB ACS550 | ID100 | ID101 |
| Terminal?? | Blue | |
| Terminal?? | White | |
| Terminal?? | Brown | |
| XYLEM CONCERTOR | ID100 | ID101 |
| Terminal?? | Blue | |
| Terminal?? | White | |
| Terminal?? | Brown | |
| SIEMENS FLOW MAG6000 | ID200 | |
| Terminal 93 | Blue | |
| Terminal 92 | White | |
| CARLO GAVAZZI EM430 BIMÅLER | ID10 | |
| Terminal 9 | Blue | |
| Terminal 8 | White | |
| Terminal 10 | Brown | |
| KAMSTRUP MÅLER | | |
| Terminal 137 | Blue | |
| Terminal 138 | White | |
| Terminal 139 | Brown | |

Displays

Display 2,4" OLED

SPIDER comes with two different types of displays but can also work without a display.

Display for direct mounting on SPIDER is a 2.4 "OLED display. The display has different screen settings and can be operated with the joystick on the right side.

There is a pause screen which disables the normal screen display after 5 minutes. After this it goes to the screen saver picture where level is displayed in different places on screen.

Installation instructions.

For correct installation, remove the transparent front cover on the SPIDER. The interface module is then clicked on, so that the joystick is located to the right.

Menu structure for the 2,4" OLED Display

Coming soon



Display EAGLE HMI 7"

SPIDER can also be delivered with a larger 7" HMI display where a larger graphic image can be designed. It is possible to design customized graphics.

A serial overprint is required. This is easily clicked on the SPIDER as well as cable sets and HMI display.

SPIDER HMI kit incl. cable sets, SPIDER serial print incl. 1.5m cable set



Installation guide

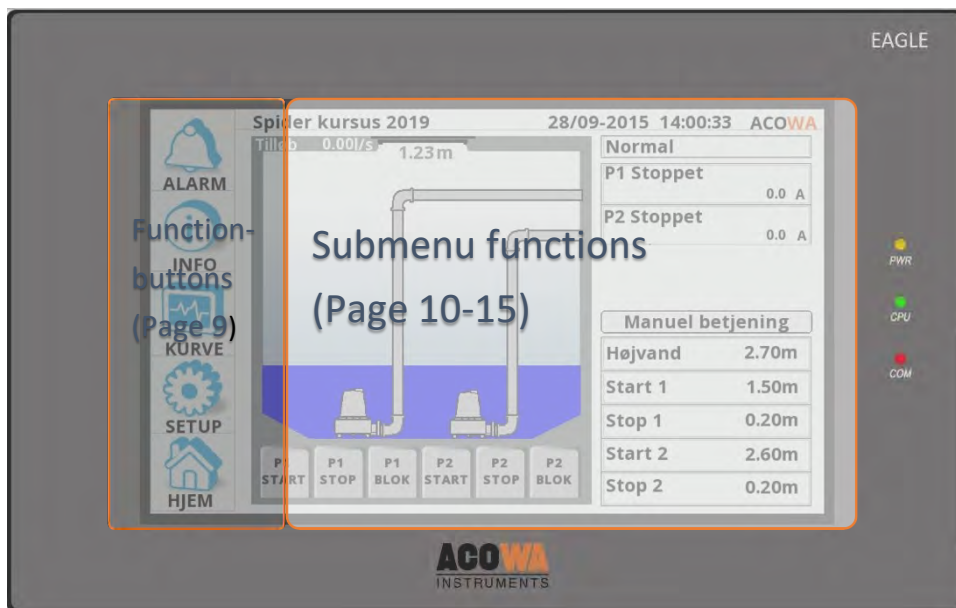

EAGLE HMI is not be supplied via the internal power supply of SPIDER. We recommend a 24V DC power supply of min. 500mA.

Menu structure for 7" EAGLE HMI Display



Function buttons

| | |
|---------------------|---|
| <p>HOME</p> | <p>HOME Overview image of the pumping station. At startup, the controller will start in this page. The panel reads the setup configuration in SPIDER and creates the image from it (Page 11)</p> |
| <p>SETUP</p> | <p>SETUP This menu contains all submenus for manual setup of the controller (Page 12)</p> |
| <p>GRAPH</p> | <p>GRAPH The submenu contains graphs of level, inlet flow, Power P1 and Power P2 (Page 15)</p> |

| | |
|---|--|
|  INFO | INFO The submenu contains data for all counters, meters and status bits on in- and outputs (page 16) |
|  ALARM | ALARM Alarm list of all alarms (Page 16) |

LED lights

When installed correctly, the upper "PWR" lamp will have a solid yellow light. The middle "CPU" will flash green and the bottom "COM" will flash rapidly red.

HOME.

The home screen is the overview picture for the entire pumping station.

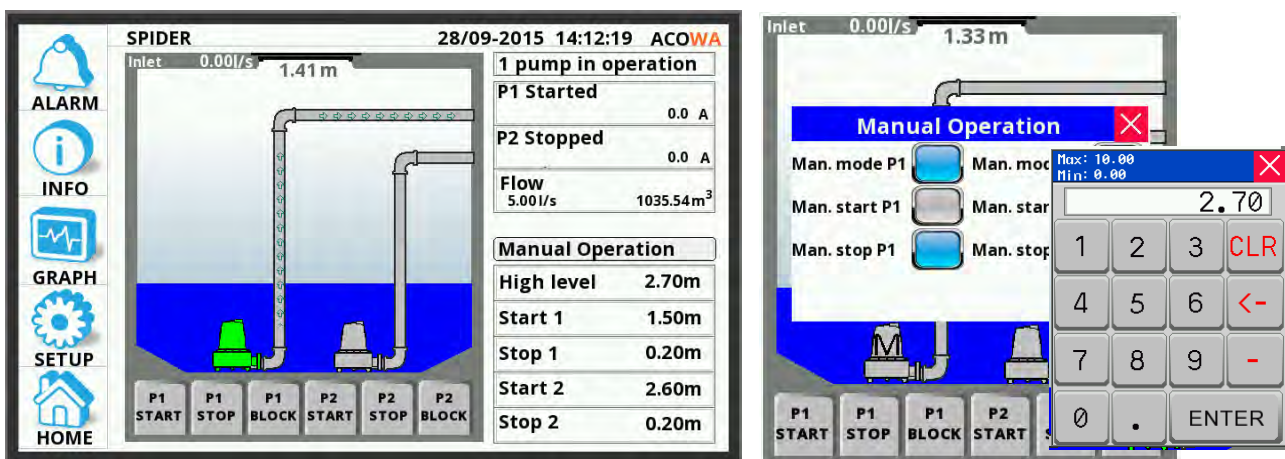

In the upper part of the picture, is the pump station data placed. In this case, the station is called SPIDER followed by date and time.

On the left side of the picture, the pump station is shown. At the top left corner is the inlet flow in l/s and next to it the current level.

Below this, the pumps are shown. If the pump is marked in a GREEN color, it indicates the pump is running. If the pump is YELLOW, this means the pump is blocked. If the pump is RED, this means the pump is in error.

At the bottom left corner, the function buttons for the pumps is shown.

P1 / P2 start: Starts the respective pump and pumps down to the stop level.

P1 / P2 Stop: Stops the respective pump if it is in operation.

P1 / P2 block: Blocks the respective pump. It can be put into service again by pressing start or via SCADA.

At the top right corner of the picture, is the status of the pump station located. If there is power measurement on the pumps, amp consumption off the pump will be displayed when the pump is operating. If inverters are used, data from these will also appear here. Flow is also shown here.

Below the status screen is the setting options, as well as manual operation of the pumps.

Pressing “manual operation” opens a new window for manual operation of the pumps. Here you choose which pump you want to operate manually. If manual operation of the pumps is selected, this will be indicated by an “M” mark on the pump picture. By selecting Man. Start P1/P2, the pumps will run until either Man. Stop P1 / P2 is activated or if the pop-up is closed again, the pump will not stop automatically.

At the bottom right corner, you find the settings for start/stop level 1 and 2, as well as level for high water alarm. By pressing the bar with the settings value, you open up a pop-up keyboard. Enter the desired setting and end with "ENTER"

SETUP.

In the SETUP menu you will find all control options for the SPIDER pump controller. At the bottom of the menu, it is possible to set the time and date in the SPIDER. If GSM / GPRS communication is used, SPIDER synchronizes the time with the mobile mast. At the bottom, it is also possible to restart both HMI and SPIDER control.

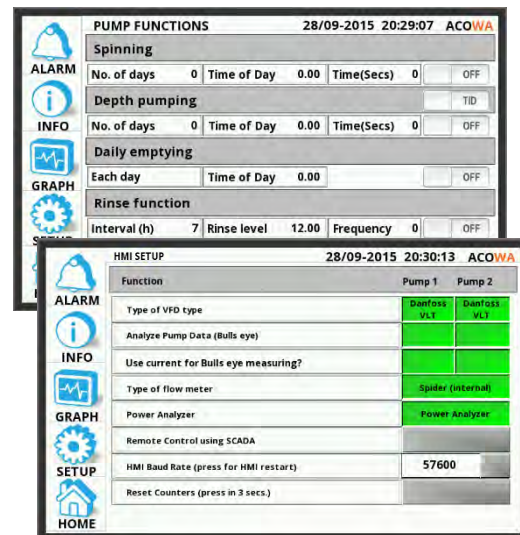
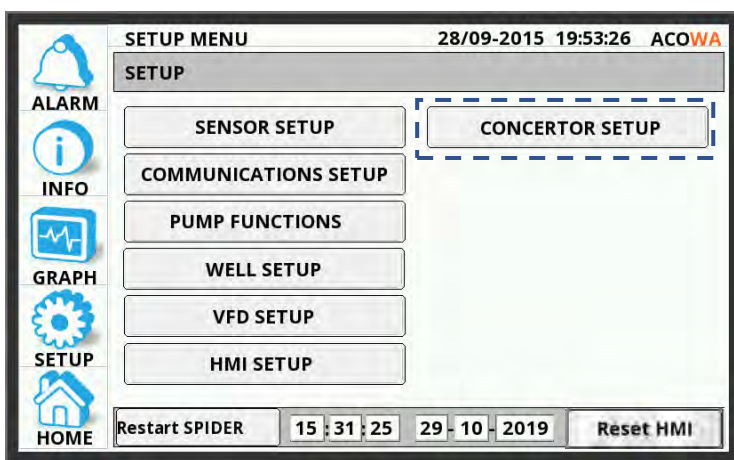

SENSOR SETUP: Used for setting AI1 input on SPIDER.

| Sensor input (4-20 mA) | | | | |
|------------------------|-----------|--------|------------|------------|
| Level Sensor | Averaging | 0 sec. | Min +0.00m | Max +5.00m |

COMMUNICATION SETUP: This menu contains the modem settings. Here you find the IP address, GSM/GPRS signal strength, APN and it is also possible to reset the modem.

| Modem settings | | | |
|---------------------|--------------------------|-------------|------|
| Is PIN in use? | <input type="checkbox"/> | PIN-Code | XXXX |
| IP Address | 000.000.000.000 | | |
| GSM signal strength | 0 % | Reset Modem | |
| APN | | | |

PUMP FUNCTIONS: Used if you want to use the functions - Spinning, Depth Pump, Daily emptying or Rinse function. For each function, select ON in the right box to activate the function.

Spinning: At small pumping stations, where the supply may depend on the seasons such as wells in the vacation homes, it can be helpful to get the pumps exercised at regular intervals. With SPIDER you can select this function and determine the time of day for exercise, you can also choose how many days between the last regular pumping to the next pump exercise and you can enter the duration in seconds of exercise.

| Spinning | | | | |
|-------------|---|-------------|------|--|
| No. of days | 0 | Time of Day | 0.00 | Time(Secs) 0 <input type="checkbox"/> ON |

Depth Pumping: SPIDER also supports depth pumping. Here you can choose the time of day for depth pumping, and the days between depth pumping.

| Depth pumping | | | | | TID |
|---------------|---|-------------|------|--------------|-----------------------------|
| No. of days | 0 | Time of Day | 0.00 | Time(Secs) 0 | <input type="checkbox"/> ON |

| Depth pumping | | | | | TID+NIV |
|---------------|---|-------------|------|--------------|-----------------------------|
| No. of days | 0 | Time of Day | 0.00 | Time(Secs) 0 | <input type="checkbox"/> ON |

Daily emptying: It is possible to have SPIDER run an emptying function at a fixed time of day. You select Daily emptying on/off and enter the desired time of day.

| Daily emptying | | | |
|----------------|-------------|------|-----------------------------|
| Each day | Time of Day | 0.00 | <input type="checkbox"/> ON |

Rinse function: It is possible to select an interval of whole hours between each rinse start. When the interval time is reached, the pump control is waiting for the rinse level to be reached. When the level is reached, both pumps will start, provided that no reciprocal lockout is selected on the pumps (In the AcowaZoo we call it "Only one pump running"). After start, the pumps will the run until they reach the stop level. If this feature is selected, the normal start level is ignored during the rinse function run period.

| Rinse function | | | |
|----------------|---|-------------|-----------------------------------|
| Interval (h) | 7 | Rinse level | 12.00 <input type="checkbox"/> ON |

WELL SETUP: Here you enter the design and dimensions of the pumping station. This information is used in connection to capacity calculations for the pumps and the inlet flow calculations.

| | | | | | |
|------------|--------------------------|-------------------------------------|------------|------|--------------------------|
| Well Shape | | <input checked="" type="checkbox"/> | Well Shape | | <input type="checkbox"/> |
| Well Shape | <input type="checkbox"/> | <input checked="" type="radio"/> | Length | 0 mm | |
| Diameter | ∅ | 1200 mm | Width | 0 mm | |

VFD SETUP: In this menu it is possible to read the reference points for the frequency converter, and to set the frequency converter max and min. frequency. This provided the converter type is selected under the "HMI SETUP" menu.

Energy mode: When the start level is reached, the pumps will run at the desired maximum set frequency until the level change entered is achieved. When this happens, the pumps will go to to the desired minimum frequency. The pumps will then be adjusted to the level changes in the station and find the optimal operating point in relation to the desired minimum frequency.

| VFD | | |
|--------|--------------|--------|
| VFD P1 | Reference P1 | 33.3Hz |
| VFD P2 | Reference P2 | 33.3Hz |

| Energy mode | | | | | |
|--------------|-----|--------------|-----|-------------|---|
| Max.frq.(Hz) | 0.0 | Min.frq.(Hz) | 0.0 | Lev. change | 0 |

HMI SETUP: In this menu, it is possible to select various control functions. Here you among others, can choose between frequency converter type, flowmeter type or choice of power analyzer.

Pressing the boxes on the left side changes the selection at each press. If the box is marked green, a change is made that deviates from a standard setup. The choices are made for both pump 1 and pump 2.

Frequency converter type: The SPIDER pump controller can communicate with several different types of frequency converters via ModBus. This includes: Schneider Altivar - Danfoss VLT - ABB ACS550 - Xylem Concertor Master or Xylem Concertor Slave.

Concertor MASTER - (Level through APP411 module) - is to be discontinued: In this function, the Concertor module control the pump. Start/stop is based on the values of Concertor modules and control is done completely autonomously via Concertor. It is possible to force-stop the pump, but you cannot force-start the pump. It is possible to calculate inlet flow, with precaution to the regulation from the Concertor. You can also read and write to selected Concertor registers. Ex. Set-Power (in operation read RPM, Amp, KW). You can enter "Start 1/Stop 1" levels via SPIDER/HMI. The Concertor APP411 module determines the start 2 level (+ 10cm to start 1 at maximum speed.)

For two or more pumps - If the water level increases 10 cm (4 inches) above the initial level of the first pump, then another pump starts at maximum speed. The speed is adjusted so that the inflow corresponds to the outflow. If the water level increases 4 cm (1.6 inches) more, a third pump will start and regulates in the same way as the second pump. This is also repeated for a fourth pump.

When selecting the Concertor Master function, a new submenu opens under the SETUP menu called Concertor setup.

Concert Slave - (Level via SPIDER): In this function mode, the SPIDER controls the pump and performs start/stop of the pump, including the start/stop levels. The pump does not control the regulation itself, this is controlled by the SPIDER. It is not possible to write to Concertor while it is in operation. In this mode, it is possible to force stop and force start the pump. Level is entered in the SPIDER - Flow calculation (inlet + outlet) can be performed, and it is possible to read and write to selected Concertor registers. Ex. Set-Power (for operation read RPM, Amp, KW)

| Function | Pump 1 | Pump 2 |
|------------------|-------------------|-------------|
| Type of VFD type | Schneider Altivar | Danfoss VLT |

Bullseye: If this function is selected, the system is set to learn during each pump operation. Subsequently, data on the pump operating point is collected at each pump start. Any change in the pumps operating points can give an indication of whether the pump or the system is faulty. The function can return data to SCADA in 4 different operating stages for each pump.

| | | |
|--------------------------------------|-------------------------------------|-------------------------------------|
| Analyze Pump Data (Bulls eye) | <input checked="" type="checkbox"/> | <input checked="" type="checkbox"/> |
| Use current for Bulls eye measuring? | <input checked="" type="checkbox"/> | <input checked="" type="checkbox"/> |

Normal operation: The pump's operating data indicates that the pump is operating within normal operating range.

Clogging: The pump's operating data indicates that the pump is operating at with high pressure and low capacity. There is an increased risk of the system being clogged.

Pipe failure: The pump's operating data indicates that the pump is operating with low pressure and very high capacity. There is an increased risk of a pipe failure.

Pump service: The pump's operating data indicates that the pump is operating with low pressure and low capacity. There is an increased risk of a pump failure that requires service.

Type of flowmeter: Here is selected whether flow measurement is wanted through the SPIDER internal capacity calculations or if an external Siemens flow meter is installed via ModBus.

| | | | |
|--------------------|-------------------|--------------------|---------|
| Type of flow meter | Spider (internal) | Type of flow meter | Siemens |
|--------------------|-------------------|--------------------|---------|

Power analyzer: Is to be selected, if a Carlo Gavazzi EM340 400VAC power meter with ModBus is installed.



Remote control using SCADA: Transfers data from external equipment via ModBus from HMI to SPIDER, so data can be read from SCADA.



HMI Baud Rate: Sets the BAUD RATE for HMI. The Standard configuration is 57600, make sure that baud rate on external equipment supports this speed. After a change, HMI must be restarted before change takes effect.



Reset counters: Resets all counters in the SPIDER with a press of more than 3 secs.



GRAPH.

In this menu you will find graphs for level, inlet, Power P1 and Power P2. Be aware that graphs are reset every time the HMI loses power or restarts.

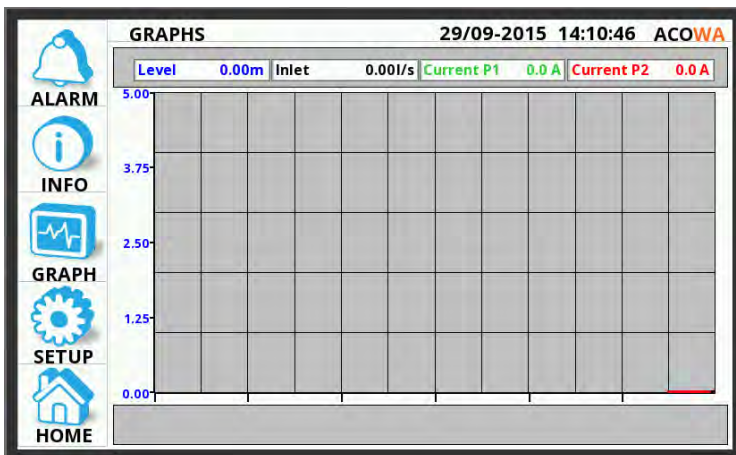

NFO Menu.

The menu contains data for all counters, meters and status bits on inputs and outputs

| INFORMATION | | | | | | 29/09-2015 14:11:06 ACOWA | | |
|--------------|--------|--------|------|------|------|---------------------------|-----------------------|--|
| Pump Data | Pump 1 | Pump 2 | Rain | kWh | Flow | | | |
| Total Starts | 7020 | 7025 | 0.0 | 20.3 | 0.00 | | | |
| Starts Today | 298 | 299 | 0.0 | 0.1 | 0.00 | | | |
| Starts Y.day | 622 | 621 | 0.0 | 0.4 | 0.00 | | | |
| Total Hours | 199.13 | 200.75 | | | | | Power Analyzer | |
| Hours Today | 2.10 | 3.51 | | | | | Status | |
| Hours Y.day | 4.39 | 4.38 | | | | | | |
| Total Vol. | 1074 | 26 | | | | | | |
| Today Vol. | 36.85 | 0.00 | | | | | | |
| Y.day Vol. | 76.28 | 0.00 | | | | | | |
| Capacity l/s | 5.00 | 0.00 | | | | | | |

| Power Analyzer | | | | | 29/09-2015 14:11:51 ACOWA | |
|----------------|-------------|-------------|-------------|-------|---------------------------|--|
| Data | Phase L1-L2 | Phase L2-L3 | Phase L3-L1 | | | |
| Voltage | 0.0 | 0.0 | 0.0 | | | |
| Data | Phase L1 | Phase L2 | Phase L3 | Total | | |
| Voltage | 229.7 | 0.0 | 0.0 | | | |
| Amps | 0.056 | 0.000 | 0.014 | | | |
| Watt | 6.6 | 0.0 | 0.0 | 6.6 | | |
| Cos φ | 0.987 | 0.000 | 0.000 | 0.987 | | |
| kWh | 20.3 | 0.0 | 0.0 | 20.3 | | |

| STATUS | | | | | | | | | | | | | | 29/09-2015 14:12:14 ACOWA | |
|--------|------|------|------|------|------|--|--|--|--|--|--|--|--|-----------------------------|--|
| Status | | | | | | | | | | | | | | | |
| DI 1 | DI 2 | DI 3 | DI 4 | DI 5 | DI 6 | | | | | | | | | Emergency control | |
| | | | | | | | | | | | | | | Emergency control 2P | |
| | | | | | | | | | | | | | | Power Failure | |
| | | | | | | | | | | | | | | Error P1 + P2 | |
| | | | | | | | | | | | | | | Error P1 + High water level | |
| | | | | | | | | | | | | | | Error P2 + High Water Level | |
| | | | | | | | | | | | | | | Power Fail 230 VAC | |
| | | | | | | | | | | | | | | Sensor fall | |
| | | | | | | | | | | | | | | One pump operating | |
| | | | | | | | | | | | | | | Two pumps operating | |
| | | | | | | | | | | | | | | 2 pump controller | |

In the menu you can see all data for the pumping station. Here is the status of the number of starts, the number of hours and quantities included yesterday, today and total values. In addition, capacity is shown on both pumps.

If a power meter is connected, pressing the "Power analyzer" bar will show a submenu with data for this.



The same will happen by pressing the "STAUS" bar. This opens a submenu that shows the status of the inputs and outputs on the SPIDER and the SPIDER I/O module if this is connected. It also shows the alarm status of the pump station on the right.



ALARM.

In this menu all alarms for the pumping station are displayed. All alarms have a description, start time and end time. The alarm list will be reset if the SPIDER loose power or by reset of the SPIDER.

| ALARM LIST | | | | 29/09-2015 14:20:10 ACOWA | |
|------------------|---------------------|---------------------|--|---------------------------|--|
| Alarm Text | Start Time | End Time | | | |
| Hejvandsalarm | 29/09-2015 16:15:11 | | | | |
| Lav niveau Alarm | 29/09-2015 14:47:55 | 29/09-2015 16:13:00 | | | |
| | | | | | |
| | | | | | |
| | | | | | |
| | | | | | |
| | | | | | |

AcowaZoo

Connecting to a PC

USB connection

SPIDER connects to the PC via a Micro-USB connector on the side of the device. The AcowaZoo will then connect to the device for configuration. When the AcowaZoo program starts, it will continuously try to establish contact with a SPIDER device via USB connection.

TCP Connection

To connect to AcowaZoo-Tool via TCP, it must first be set to the correct TCP settings (IP Address, Port, APN). This is done in the AcowaZoo via the USB port. Once the SPIDER is configured correctly, then it can be accessed from the AcowaZoo via TCP.

AcowaZoo Installation

Driver installation

Before installing AcowaZoo on a computer running Windows 7 or Windows 8, an additional driver file for communication via the USB port must be installed.

Right-click on the file "fsl_ucwpx.inf" and select "install". Windows will ask for permission to install. The file is located in the "driver" folder under the " AcowaZoo-Tool " folder.

Program installation

AcowaZoo can be installed on computers running Windows 7, 8, or 10 or newer. Run the program "**AcowaZooSetup.exe**" ("AcowaZooSetup_32bit.exe" on 32-bit operating systems) and follow the on-screen instructions:

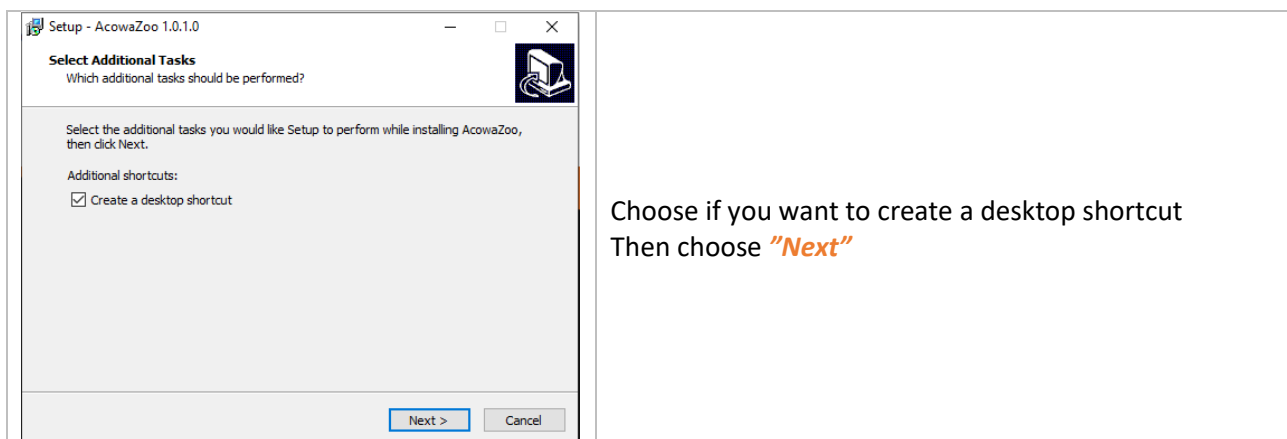

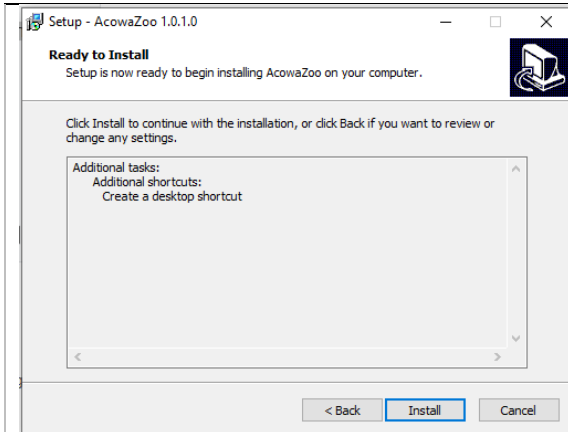

Choose **"Install"**

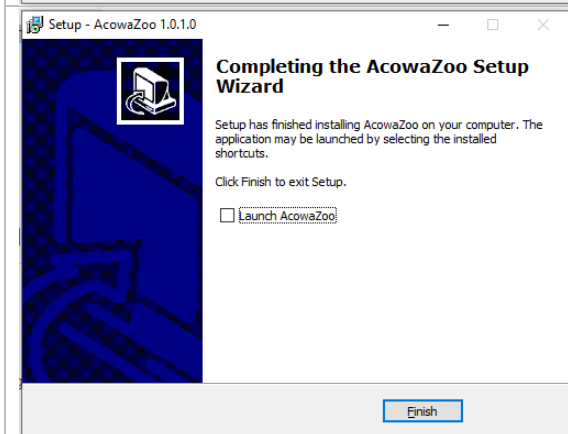

Choose whether to start ACOWA ZOO-Tool after installation.
Then choose **"Finish"**

Setup



AcowaZoo user interface

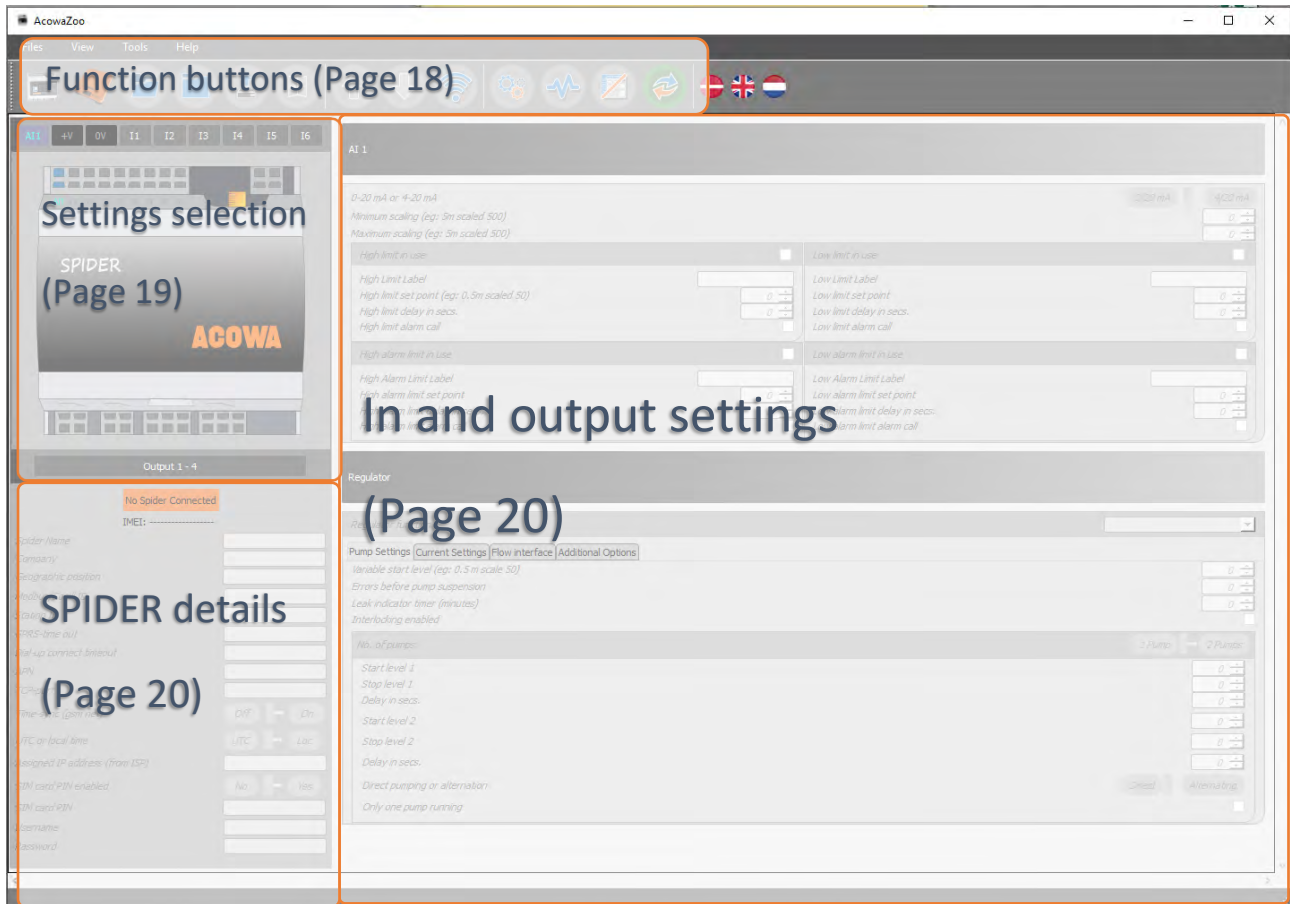

Overview



Function buttons

Functions associated with writing and reading from SPIDER and disk, as well as contact with SPIDER via TCP.

| | |
|---|---|
|  | <p>Open Local Config File Load configuration from hard drive, USB drive, etc.</p> |
|  | <p>Save Local Config File Save configuration on hard drive, USB drive, etc.</p> |
|  | <p>Load Default Configuration Select and load a typical SPIDER configuration (control of 1 or 2 pumps, groundwater lowering, etc.)</p> |

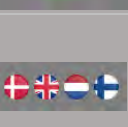
| | |
|---|---|
|  | <p>Backup function Mirrors the counters etc. in the SPIDER controller. (Is used for updating or replacement of the modem)</p> |
|  | <p>Load Config from Device. Load settings from the connected SPIDER device.</p> |
|  | <p>Write Config to Device. Writes the current settings to the connected SPIDER device</p> |
|  | <p>Establish TCP connection to the device Establishes TCP communication with a SPIDER device (With the 2G SPIDER version it disconnects any USB connection)</p> |
|  | <p>Device settings Advanced settings. (Further description on page 28.)</p> |
|  | <p>Show status. Supervision and status bits. (Further description on page 30.)</p> |
|  | <p>Toggle Graphical and Schematic view Toggle between displaying graphical menu settings and displaying schematic settings (overview of ModBus registers in SPIDER device)</p> |
|  | <p>New AcowaZoo version available. Update AcowaZoo firmware (Is only shown when a newer version is available)</p> |
|  | <p>Language Options Select application language.</p> |

Function menu

Files

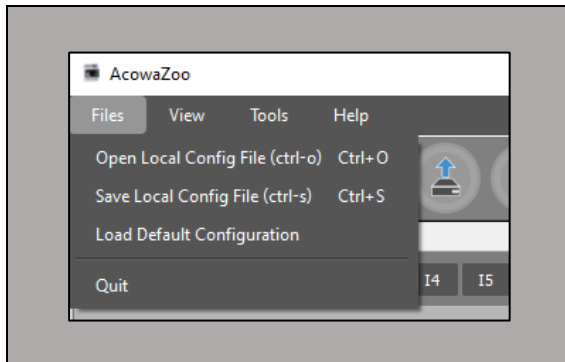

Open local config file:

Ability to load previously saved configurations

Save local config file:

Ability to store configurations locally.

Load default configuration:

Loads a default file that you can continue working on.

View

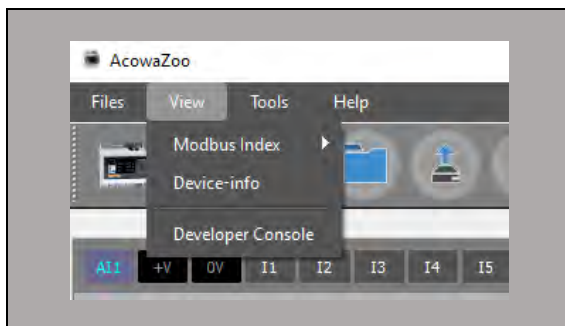

ModBus index:

Here it is possible to choose either register view or address view. The selected parameters will then appear next to each function. See the example below.

Device info:

Displays the firmware version

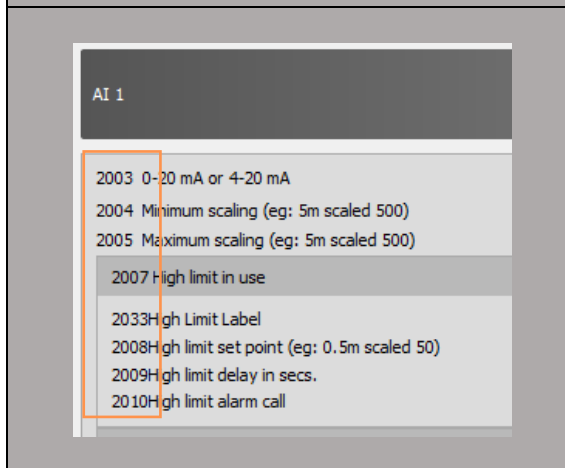

ModBus registers:

The selected parameters are displayed next to each function. The figures change in relation to choice of address or registers

Tools

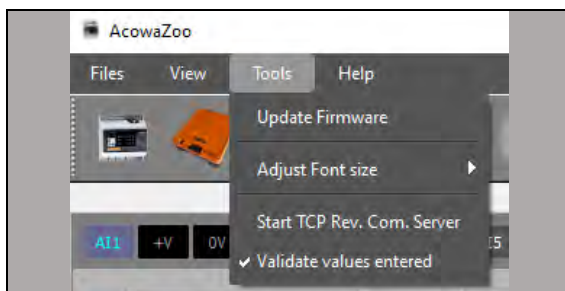

Update Firmware:

Here, device firmware is updated. See below for instructions.

Adjust Font Size:

Here, font size can be enlarged or reduced.

Device firmware update.

| | |
|--|--|
| | <p>Acowa firmware updater: When choosing a firmware update, AcowaZoo shuts down and opens an update software instead. Connect the desired device via the USB port.</p> <p>The status will change to: USB connected.</p> <p>Then press the folder "Open"</p> |
| | <p>Select the required firmware file and press "Open"</p> |
| | <p>The status is then changed to: Firmware loaded.</p> <p>Now click on the "Flash" icon</p> |
| | <p>The status is then changed to: Flashing.</p> <p>When the device is updated, it will state: Successfully flashed. The program then has to be closed down and AcowaZoo is to be reopened.</p> |

Help

| | |
|--|---|
| | <p>User manual: Opens a user manual</p> <p>About AcowaZoo: Displays the version version of AcowaZoo</p> |
|--|---|

Settings selection



Here you select which part of the SPIDER device's settings to display in the settings window on the right.

AI1:
Analog Input settings.

I1 - I6:
Input Settings 1-6

Output 1-4: Output Settings 1-4

SPIDER details

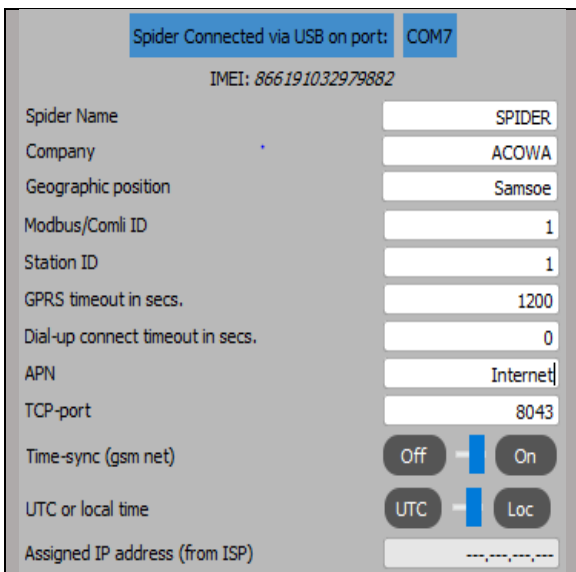

Here you are notified if a SPIDER is connected and what types of connection are involved:

- USB on COM port
- TCP at Ip address / port

At the same time, details of the SPIDER device name and location are displayed/set, as well as communication settings.

- APN
- TCP-port

Input and output Settings

This section describes the settings for inputs and outputs as well as other logic in the SPIDER unit. The individual pages are selected in Settings selection (see above)

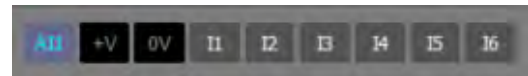
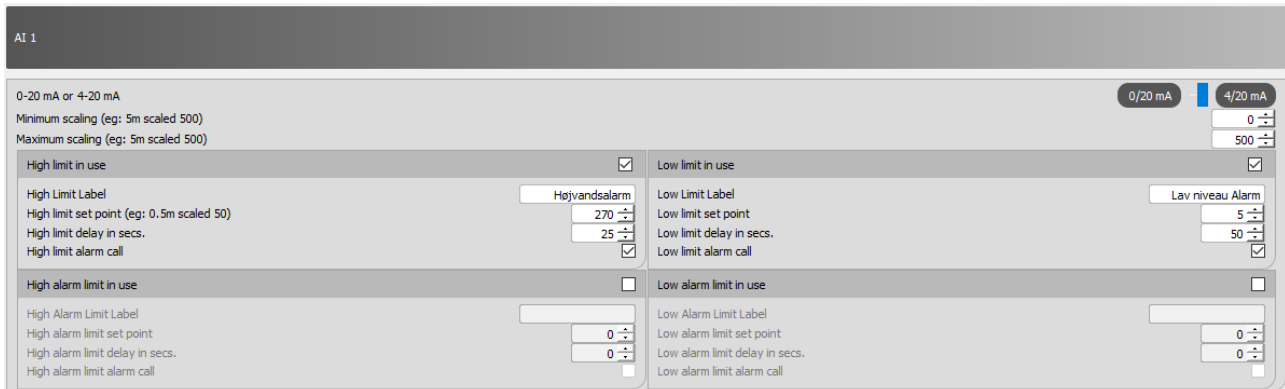
Analog Input (AI1)

The analog input in the SPIDER is a standard 0-20/4-20mA input to which a pressure transmitter or other measuring equipment can be connected.

The input functions can be set in AcowaZoo-Tool when AI1 is selected in the Settings selection. AI1 contains the following settings:

| AI 1 Settings | Functions | Description |
|---------------------------|--|--------------------------------|
| 0-20mA or 4-20mA | Scaling input defined by measurement equipment | |
| Minimum scaling | Minimum measurement reading value | With 2 decimals (500 = 5,00) |
| Maximum scaling | Maximum measurement reading value | With 2 decimals (500 = 5,00) |
| High limit in use | Activates high limit functions | 0=disabled, 1=activated |
| High limit label | Naming the high limit value | Used in alarm list and SMS |
| High limit Set point | Defines high limit value | |
| High limit delay in secs. | Signal delay | Stated in seconds |
| High limit alarm call | Activates alarm signal | 0=Local signal, 1=alarm signal |
| Low limit in use | Activates low limit functions | 0=disabled, 1=activated |
| Low limit label | Naming the low limit value | Used in alarm list and SMS |
| Low limit Set point | Defines low limit value | |
| Low limit delay in secs. | Signal delay | Stated in seconds |
| Low limit alarm call | Activates alarm signal | 0=Local signal, 1=alarm signal |

The scaling of AI1

It is possible to choose between 2 types of mA measurements. Either "0-20 mA" or the most common "4-20 mA". Min./Max. scaling points is entered at the desired resolution. For example, if a pressure transmitter with a measuring range of 0-5m is used, and you need to read the level in cm. Enter min. = 0 and max. = 500.

Limit relay values

Limit relay values can be configured for high/low limit levels. For both types of limits the function can be activated/deactivated, and the limit relay can be named with a label used as text in an alarm list and in SMS alerting.

Values can be set to which level the high/low limit relays are activated, and a delay can be attached, so that a limit value must be exceeded for a given time before the signal is registered as active. It is possible to choose whether to send the signal as an alarm or to act as a local alarm.

Digitale Input (I1–I6)

The I1-6 inputs on the SPIDER are standard 0-10 V inputs, or standard digital inputs where “0” is <5V and “1”> 12V.

The input functions can be set in AcowaZoo-Tool when I1-6 is selected in the Settings selection. I1-6 contains the following settings:



| DI/VI 1-6 Settings | Functions | Remarks |
|------------------------------|---|--------------------------------|
| Signal label | Name of the signal | Used in alarm list and SMS |
| Input 1/6 – function | Selection of predefined functions | |
| Normally open / closed | The polarity of the signal | |
| Delay for ON-state in secs. | Signal delay | Stated in seconds |
| Delay for OFF-state in secs. | Signal delay | Not in use |
| alarm signal | Activates alarm signal | 0=Local signal, 1=alarm signal |
| VI settings | | |
| minimum scaling | Minimum measurement reading value | With 1 decimal. (20 = 2,0) |
| maximum scaling | Maximum measurement reading value | With 1 decimal. (20 = 2,0) |
| Middling in seconds | middling of the measurement reading value | |
| High limit in use | Activates high limit functions | 0=disabled, 1=activated |
| High limit label | Naming the high limit value | Used in alarm list and SMS |
| High limit Set point | Defines high limit value | |

| DI/VI 1-6 Settings | Functions | Remarks |
|---------------------------------|--------------------------------------|--------------------------------|
| High limit delay in secs. | Signal delay | Stated in seconds |
| High limit alarm call | Activates alarm signal | 0=Local signal, 1=alarm signal |
| High alarm limit in use | Activates high Alarm limit functions | 0=disabled, 1=activated |
| High alarm limit label | Naming the high limit alarm | Used in alarm list and SMS |
| High alarm limit Set point | Defines high limit alarm value | |
| High alarm limit delay in secs. | signal delay | 0=Local signal, 1=alarm signal |
| High alarm limit alarm call | Activates alarm signal | 0=Local signal, 1=alarm signal |
| Low limit in use | Activates low limit functions | 0=disabled, 1=activated |
| Low limit label | Naming the low limit value | Used in alarm list and SMS |
| Low limit Set point | Defines low limit value | |
| Low limit delay in secs. | Signal delay | Stated in seconds |
| Low limit alarm call | Activates alarm signal | 0=Local signal, 1=alarm signal |
| Low alarm limit in use | Activates low limit alarm functions | 0=disabled, 1=activated |
| Low alarm limit label | Naming the low limit alarm value | Used in alarm list and SMS |
| Low alarm limit Set point | Defines low limit alarm value | |
| Low alarm limit delay in secs. | Signal delay | Stated in seconds |
| Low alarm limit alarm call | Activates low limit alarm signal | 0=Local signal, 1=alarm signal |

Functions for I1-6:

Standard DI function: Can be used to count pulses or check the state of a desired digital signal.

Standard VI function (0-10V): Can be scaled, the scaled value can be displayed. High/low limits are attached to the signal, which can trigger an alarm if the limits are exceeded.

Klixon for P1/P2: Used in connection with pump control where the input can be configured as an alarm signal that stops the faulty pump. The state of Klixon can be read in the Pump Status word on bit 2.

Thermal error P1 / P2: Used in connection with pump control, where the input can be configured as an alarm signal that stops the faulty pump. The state of the Thermo relay can be read in the Pump Status word bit 1.

High-level switch: Used as a start signal for emergency control of the pumps in case of faulty level transmitter. The state of the high-level switch can be read on the Spider status word bit 26. (High level switch version 2 see page 43.)

Pump running P1/P2: used as feedback signal for the pump control. If the corresponding output on SPIDER is drawn, but the operating signal fails for more than 1 min. the pump is stopped. The state of the operating signal can be read in the pump status word at bit 0.

Power measurement P1/P2: Used as an operating feedback. If the corresponding output on SPIDER is drawn, but "low limit" is still indicated for more than 1 min. the pump is stopped. The state of the operating signal can be read in the pump status word at bit 0.

Manual mode P1/P2: Disables the auto function for the pump when the signal is active. The signal typically comes from an "Auto-0-Man" switch. The condition of "out of auto" can be read on the pump status word bit 3.

IO expansion: Can only be used on I1 and I2, thus increasing the number of digital inputs up to 12. On the additional Digital inputs, the following functions can be selected: Standard DI, Klixon, Thermal error, pump running, manual mode and high-level switch.

Intensity: used in relation to rain gauges, where you can read the following values: Total counts of pulses, today counter and yesterday counter. The values can be read on reg. address 256, 258, 260. At each pulse on the input, the value increases with the entered value for VI settings - Maximum Scaling.

PIR: stands for Passive InfraRed sensor. This feature is typically used with a digital output that has the “Fan” function. When the PIR input is activated, the fan starts up and runs for a specified time.

Heat sensor: Typically used with a digital output that has the function "Heat control". The input typically has a heat sensor fitted which gives a 0-10V output signal. The input is scaled according to what 0V and 10V correspond to. This defines a low limit at which the heat control must be activated and a high limit at which heat control is deactivated.

Valve opened: Used with a digital output that has the function "Open valve", the function is used with another set of DI/DO, where you can open and close a valve that stops the supply to the pump well, whereby the inlet pipes can be used as reservoirs in case of increased inflow/rain event etc.

Valve closed: Used in conjunction with a digital output that has the "Close valve" function. Read the description above.

General stop: Used as a general stop function. If the digital goes high it stops the pumps. Can be used in case of “dry running” of pumps, where a mechanical stop is activated and stops the pumps.

I/O extension DI1-DI4 and DI5-DI8: Used in connection with DI1 and DI2 when using the SPIDER I/O extension module. The selection opens for the above setting options for each input.

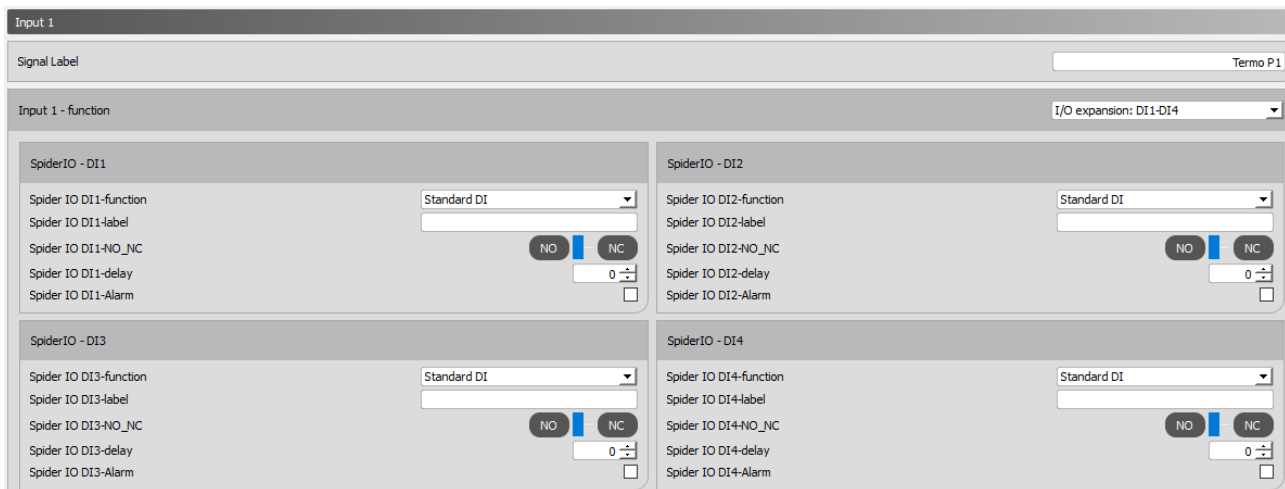

The screenshot displays the configuration page for 'Input 1'. At the top, there is a 'Signal Label' field containing 'Termo P1'. Below this, the 'Input 1 - function' is set to 'I/O expansion: DI1-DI4'. The main area is divided into four panels, each for a SpiderIO channel (DI1, DI2, DI3, and DI4). Each panel contains the following settings:

- Spider IO [DI]-function:** A dropdown menu set to 'Standard DI'.
- Spider IO [DI]-label:** An empty text input field.
- Spider IO [DI]-NO_NC:** Radio buttons for 'NO' (selected) and 'NC'.
- Spider IO [DI]-delay:** A numeric input field set to '0'.
- Spider IO [DI]-Alarm:** An unchecked checkbox.

VI (0-10V) I/O exp: AI1 and AI2: Used in connection with DI3 and DI4 when using the SPIDER I/O expansion module. The selection opens for the setting options below for each input.

| | |
|--|---|
| Input 3 | |
| Signal Label | Strøm P1 |
| Input 3 - function | VI (0-10V) I/O exp: AI1 |
| DI Settings | |
| Normally Open - Normally Closed | Normally Open |
| Delay for ON-state in secs. | 0 |
| Delay for OFF-state in secs. | 0 |
| Alarm call | <input type="checkbox"/> |
| VI Settings | |
| Minimum scaling (eg 20A scaled 200) | 0 |
| Maximum scaling (eg 20A scaled 200) | 200 |
| Averaging in secs. | 5 |
| High limit in use <input checked="" type="checkbox"/> | High alarm limit in use <input type="checkbox"/> |
| High limit Label: Høj Strøm P1 | High Alarm Limit Label: |
| High limit setpoint (eg: 1m scaled 10): 200 | High alarm limit setpoint (eg: 1m scaled 10): 0 |
| High limit delay in secs.: 5 | High alarm limit delay in secs.: 0 |
| High limit alarm call: <input type="checkbox"/> | High alarm limit alarm call: <input type="checkbox"/> |
| Low limit in use <input checked="" type="checkbox"/> | Low alarm limit in use <input type="checkbox"/> |
| Low limit Label: Lav Strøm P1 | Low Alarm Limit Label: |
| Low limit setpoint (eg: 1m scaled 10): 10 | Low alarm limit setpoint (eg: 1m scaled 10): 0 |
| Low limit delay in secs.: 0 | Low alarm limit delay in secs.: 0 |
| Low limit alarm call: <input type="checkbox"/> | Low alarm limit alarm call: <input type="checkbox"/> |

Digital output



DO 1-2 are relay outputs dedicated to pump control, where DO 3-4 is used for specialized functions.

To configure DO 1-4 click on the button shown below the Spider image.

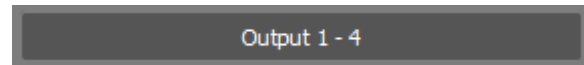

| DO 1 and 2 settings | Functions | Description |
|-----------------------------|---|-----------------------------------|
| Constant or timed | Choose if DO should be activated for a given period of time | Can be used for timely operations |
| ON-timer in secs. | If timed is chosen, state the wanted period of time | On-timer stated in seconds. |
| Delay for ON-state in secs. | Signal delay | Delay stated in seconds. |

| DO 3 and 4 settings | Functions | Description |
|-----------------------------|---|-----------------------------------|
| Function | Additional functions | Could be alarm, Washing pump etc. |
| Constant or timed | Choose if DO should be activated for a given period of time | Can be used for timely operations |
| ON-timer in secs. | If timed is chosen, state the wanted period of time | On-timer stated in seconds. |
| Delay for ON-state in secs. | Signal delay | Delay stated in seconds. |

Functions for DO 3-4:

Not used: The digital output has no function associated, so the output can be used freely and can be controlled from SCADA.

Pump 1 (mirror): The output is triggered when P1 is running but is subject to its own delay, if selected, on-timer.

Pump 1 error: The output is high if P1 is faulty.

Pump 2 (mirror): The output is triggered when P2 is running but is subject to its own delay, if selected, on-timer.

Pump 2 error: The output is high if P2 is faulty.

General alarm: The output is high if an active alarm is registered in the SPIDER.

Compressor function: The output can be configured to activate a compressor after the pump run has ended, and it can be selected whether the compressor should run intermittent operation or whether it should only be activated once after the pump run has ended.

For interval operation, enter the interval in address 2776. The unit is in seconds. If the value is 0, the compressor will run only once after the one-shot pump run. The operating time of the compressor is written in address 2777. This unit is also in seconds.

Washing-pump: When the output is set to washing pump function, the output will go high when pump 1 or 2 is running and the level is decreasing.

The washing pump has its own start/stop levels which are located at the following addresses:
Initial level of washing pump is approx. 2785, the unit is the same as for level measurement on AI1.
Stop level for flush pump is approx. 2786, the unit is the same as for level measurement on AI1.

The washing pump function is only activated when the level has been above the starting level and then falls below the starting level. If the level rises to more than 10% of the start level of the washing pump, it stops again and awaits a level below the start level

Dosage-pump: When pump 1 or pump 2 is running, the output will pulse, the time between each pulse is set in the parameter "Delay before ON in seconds" and the ON time of the pulse is set in the parameter "on-time by time control in seconds".

Aumagear: This function is yet to be implemented

Bassin-PST: This feature requires that a VI6 level sensor is fitted to the SPIDER. The level sensor has its own start/stop levels set in addresses 2785 and 2786. If the level in the pump sump detects a high limit of the level, the basin pump will stop. When the high limit in the pump sump disappears, a pause of xx seconds is held. This value is located at address 2776.

NOTE: The start/stop registers for basin control are also used as levels for the washing-pump function, so be aware when using basin control and washing-pump on the same SPIDER controller.

Pulse per volume unit: This function can give a pulse on a digital output based on a flow calculation, such as in overflow registration where the pumped quantity is calculated (the total amount can be read in address 250). This value can be used in conjunction with the quantity scaling in address 2794 and triggers the selected DO when there has been an increase in the total amount of the entered value for the quantity scaling.

P3 control: This function is used to control a 3rd pump based on the level measurement on AI1. The start and stop levels of this pump are given at the set points for HIGH/LOW ALARM LIMIT for AI1. The address for starting level is address 2011 and for stop level it is address 2019. It is important to activate "HIGH/LOW ALARM LIMIT IN USE" to activate the output. P3 does not have a status word associated with it and is not part of the alternate function limited to P1 and P2.

Vacuum Pump: This special feature is limited and to DI3 on the SPIDER-I/O and DO4 on the SPIDER. If the instantaneous status of DI 3-SPIDER I/O goes high, DO4 is started and runs until the instantaneous status of DI3-SPIDER I/O goes low. If the status of DI 3-SPIDER I/O remains high after "ON delay in seconds" for the input, an alarm is sent and DO 4 stops the vacuum pump.

Ventilator: This function can run interval operation with a fan. The output must be configured to be time controlled and the operation/pause times are controlled by "ON-timer by time control in seconds" and "Delay before ON in seconds". It is possible to add the possibility of triggering the fan by configuring a DI to be a "PIR" input, thereby triggering the fan immediately and running for the time configured for the output.

Heat control: This function can control a heat source based on a temperature measurement on a VI with the function "Heat sensor". The output is activated when the measured temperature is below "Low limit setpoint" and the output is deactivated when the measured temperature is above "High limit setpoint".

Mixer: This function controls a mixer to stir the sump before a pump starts. The mixer activates an output when the level of AI1 > start level of P1 and stops again when level < stop level of P1.

Reverse P1: This function can reverse P1 when the pump is manually set in the pump's status word (address 70), either via SCADA or HMI display. Reversing is done by inserting bit 22 into the pump status word.

Reverse P2: This function can reverse P2 when the pump is manually set in the pump's status word (address 70), either via SCADA or HMI display. Reversing is done by inserting bit 22 into the pump status word.

Open valve: This function must be used with a "Valve opened" function on a DI. The output is high when low level is detected on AI. The output goes low when "Valve opened" is indicated on a digital input.

The function is used in conjunction with another set of DI/DO, where one can open and close a valve that stops the inlet to the pump well, whereby the inlet pipes can be used as reservoirs in case of increased inlet/rain event etc.

Close valve: This function must be used with a "Valve closed" function on a DI. The output is high when a high level of AI is detected. The output goes low when "Valve Closed" is indicated on a digital input.

Contact device via TCP/IP

To activate the Device settings, click on the following symbol:
This results in the following window.

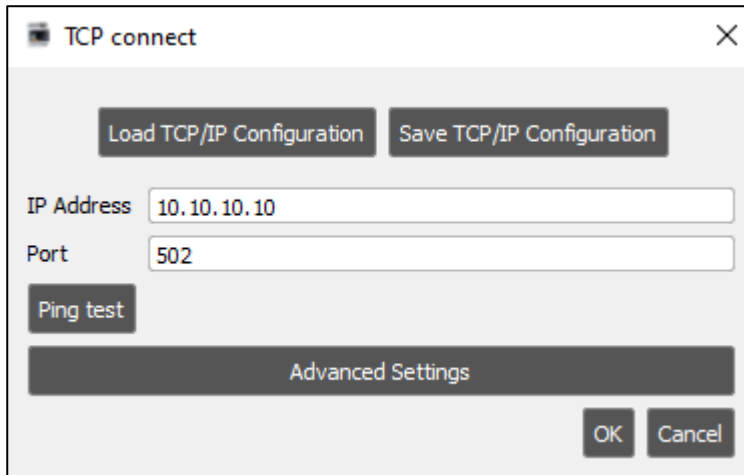
A screenshot of a software dialog box titled "TCP connect". The dialog has a close button (X) in the top right corner. It contains two buttons at the top: "Load TCP/IP Configuration" and "Save TCP/IP Configuration". Below these are two text input fields: "IP Address" with the value "10.10.10.10" and "Port" with the value "502". There is a "Ping test" button below the port field. A large, dark grey button labeled "Advanced Settings" is positioned below the input fields. At the bottom right, there are "OK" and "Cancel" buttons.

Enter the IP address and port to get remote control of SPIDER via TCP / IP. Upon contact, the program located in the SPIDER is retrieved. It is then possible to either make changes online in the SPIDER or save a copy of the current program locally and then work on it.

If you want to save your IP configuration, this is done by selecting "Save TCP / IP configuration". Note, be aware that only the IP configuration is saved and not the rest of the SPIDER setup. It is also possible to retrieve saved IP configurations using "Retrieve TCP / IP configuration"

Device settings / advanced settings

To activate the Device settings, click on the following symbol:
This results in the following window.



Reports and alarms:

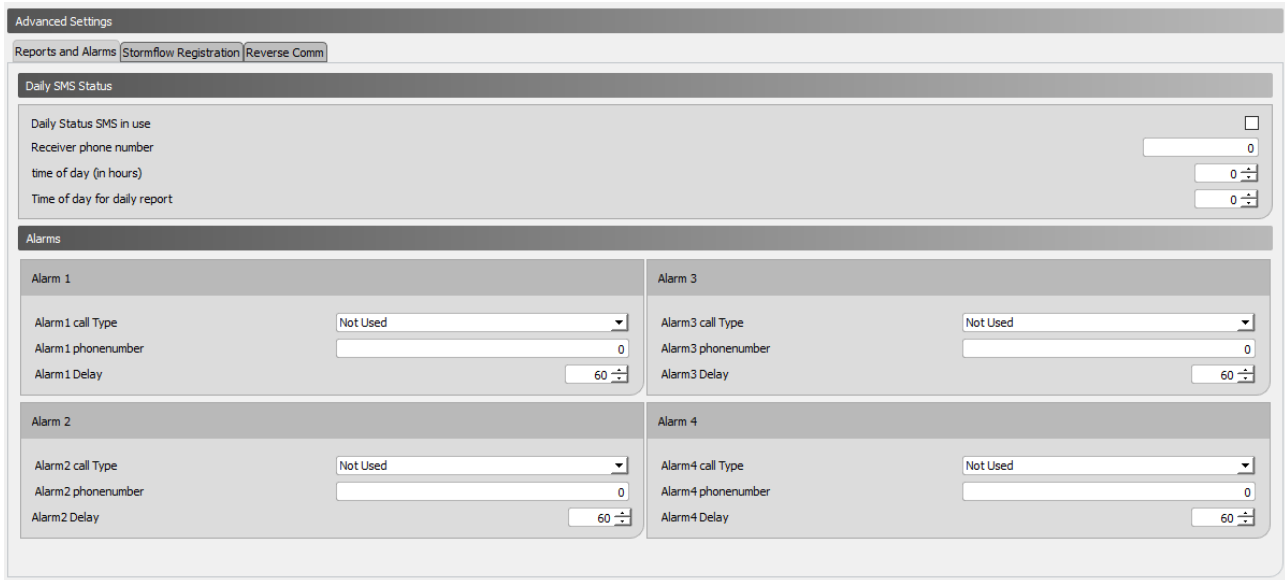

If the SPIDER is used as a stand-alone device that is not connected to a SCADA system, it is possible to receive a daily status SMS and alarm SMS in case of an alarms.

For daily status SMS, the following parameter must be used: "Daily status SMS in use" to activate the function.

"Receivers Phone Number." There is only one user who can receive a status SMS.

"Time of day (in full hours)" you want a status SMS for example 9:00 pm. enter the value 9.

Alarms can be sent to 4 different recipients. You can use SMS or standard dial-up. You must enter a delay between each alert in the list. For SMS, a typical delay of 60 sec. When using dial-up, it will typically be 300 seconds.

Reverse Comm:



In cases where you do not have an MPLS network and you have the option of having a fixed public IP address associated with your network connection, you can make SPIDER the TCP client and then connect to

the SCADA system. The IP address of the public IP address is entered along with the desired TCP port. The SPIDER will then establish a TCP connection to this address.

Stormflow registration:

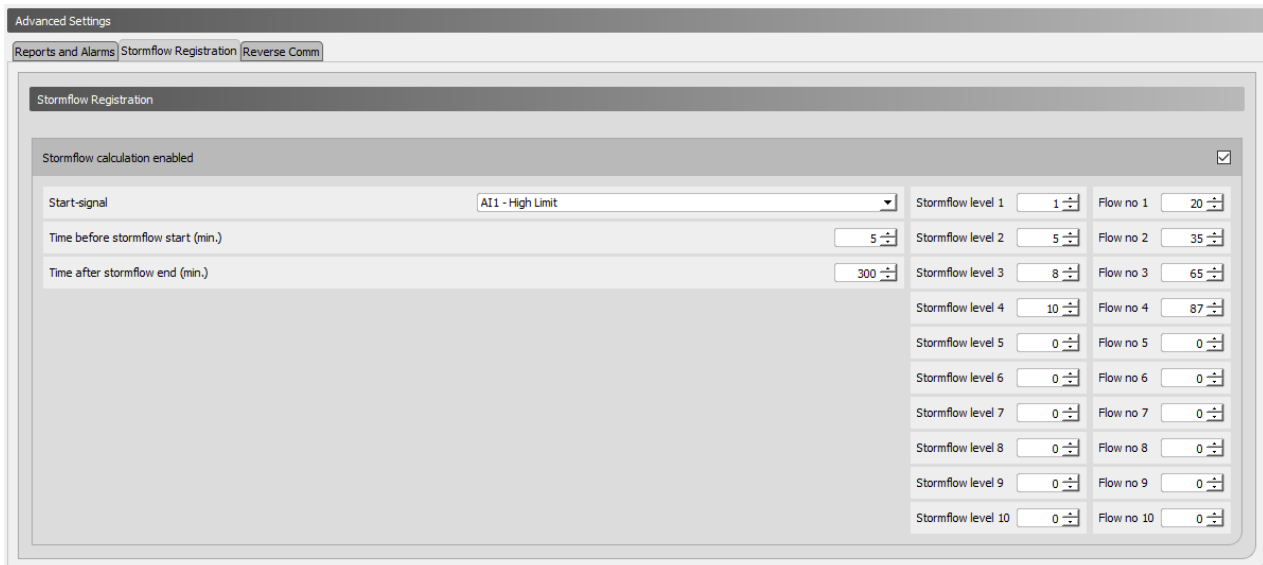

| Stormflow level | Flow no |
|--------------------|------------|
| Stormflow level 1 | Flow no 1 |
| Stormflow level 2 | Flow no 2 |
| Stormflow level 3 | Flow no 3 |
| Stormflow level 4 | Flow no 4 |
| Stormflow level 5 | Flow no 5 |
| Stormflow level 6 | Flow no 6 |
| Stormflow level 7 | Flow no 7 |
| Stormflow level 8 | Flow no 8 |
| Stormflow level 9 | Flow no 9 |
| Stormflow level 10 | Flow no 10 |

Stormflow calculation is used to record the number, duration and quantity of stormflow events.

The stormflow calculation can be used for either as a "True overflow" or "Conditional overflow".

The stormflow event "start" signal can be selected either as a high limit at AI1 or as a digital input on DI 1-6.

To use "True overflow", "Time before stormflow start (min)" and "Time after stormflow end (min)" are both set to 0.

If "Conditional" overflow is desired as shown in the picture, enter how long an overflow must be active before it is registered as a valid overflow, and how long an overflow must be completed before a new overflow is registered. In the example shown, the start time is set to 5 minutes. and an end time set at 5 hours.

The table is filled with a column for levels and a column with the flow value that matches the entered level.

The overflow levels are entered in the same unit as the level measurement on AI1 (typically in cm) and the flow is typically entered in m³/h. if you want the result with for example 1 decimal the flow values are multiplied by 10 in the table.

NOTE: it is important to start with a data set in the table that is NOT (0,0) as the SPIDER perceives (0,0) as being the end of the table.

Operation data can be found in the following addresses:

| Address | Description | Data type | Read/Write |
|---------|---|-----------|------------|
| 206 | Overflow current flow (m ³ /h) | u32 | R |
| 208 | Number of overflows total | u32 | R/W |
| 210 | Number of overflows today | u32 | R/W |
| 212 | Number of overflows yesterday | u32 | R/W |
| 214 | Duration of overflow today (seconds) | u32 | R/W |
| 216 | Duration of overflow today (seconds) | u32 | R/W |

| Address | Description | Data type | Read/Write |
|---------|--|-----------|------------|
| 218 | Duration of overflow yesterday (seconds) | u32 | R/W |
| 220 | Overflow volume total (m3) | u32 | R/W |
| 222 | Overflow volume today (m3) | u32 | R/W |
| 224 | Overflow volume yesterday (m3) | u32 | R/W |

Show Status

Online status

To activate the Online window, click on the following symbol:



This results in the following window.

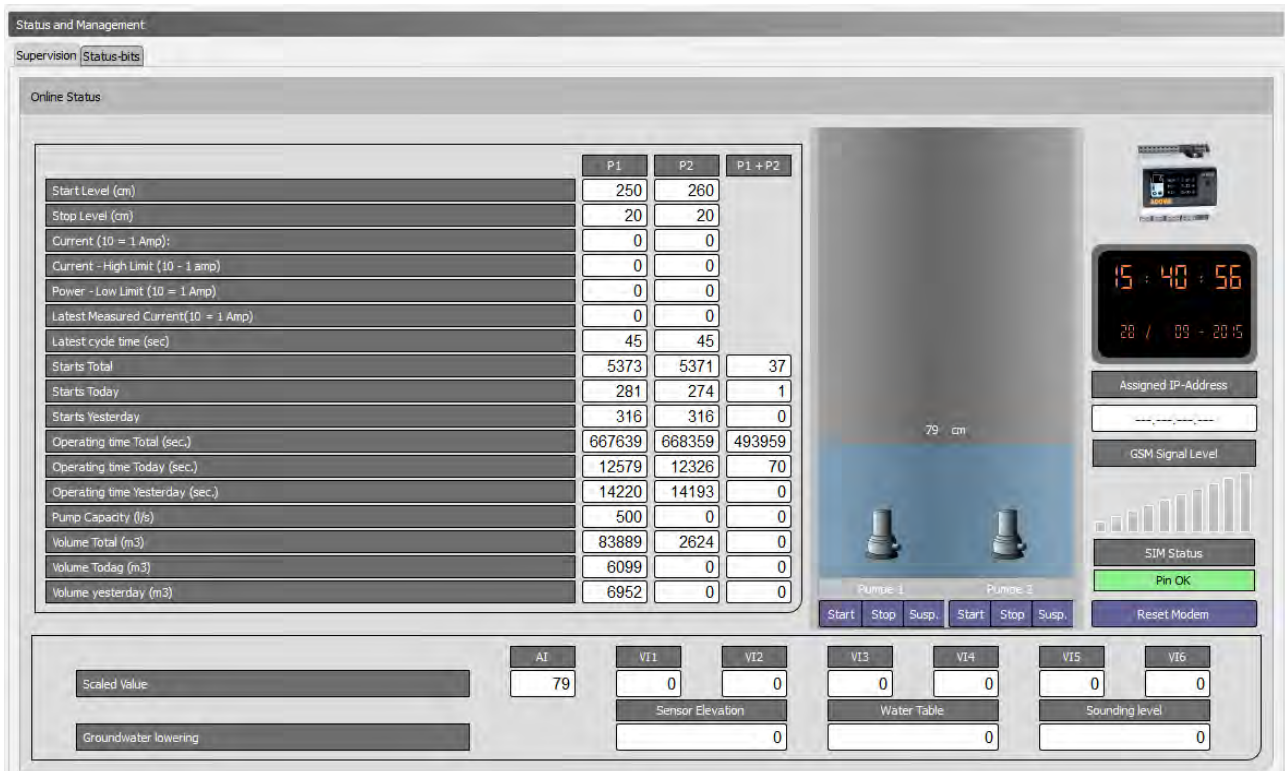

The screenshot shows the 'Status and Management' interface with the 'Supervision' tab selected. The 'Online Status' window is active, displaying a table of pump parameters, a well status visualization, and various system metrics.

| | P1 | P2 | P1 + P2 |
|-------------------------------------|--------|--------|---------|
| Start Level (cm) | 250 | 260 | |
| Stop Level (cm) | 20 | 20 | |
| Current (10 = 1 Amp): | 0 | 0 | |
| Current - High Limit (10 = 1 amp) | 0 | 0 | |
| Power - Low Limit (10 = 1 Amp) | 0 | 0 | |
| Latest Measured Current(10 = 1 Amp) | 0 | 0 | |
| Latest cycle time (sec) | 45 | 45 | |
| Starts Total | 5373 | 5371 | 37 |
| Starts Today | 281 | 274 | 1 |
| Starts Yesterday | 316 | 316 | 0 |
| Operating time Total (sec.) | 667639 | 668359 | 493959 |
| Operating time Today (sec.) | 12579 | 12326 | 70 |
| Operating time Yesterday (sec.) | 14220 | 14193 | 0 |
| Pump Capacity (l/s) | 500 | 0 | 0 |
| Volume Total (m3) | 83889 | 2624 | 0 |
| Volume Today (m3) | 6099 | 0 | 0 |
| Volume yesterday (m3) | 6952 | 0 | 0 |

The interface also shows a well status visualization with a water level of 79 cm, pump control buttons (Start, Stop, Susp.), and system metrics like Scaled Value (79), Sensor Elevation (0), Water Table (0), and Sounding level (0). On the right, there is a digital clock (15:40:56), IP address, GSM signal level, and a 'Reset Modem' button.

In the left frame, standard registers are displayed for the pump control, such as start/stop levels and operating parameters.

In the middle, well and pumps are shown, and it is possible to force start stop or block the pumps with the command buttons under the picture of the well.

On the right side, the clock in the SPIDER can be read, as well as the IP address and signal strength. It is possible to set the clock in the SPIDER by clicking on the window over time. You can also reset the modem in the SPIDER by clicking on the "Reset Modem" button.

In the bottom of the screen the scaled value of AI and V1-6 is displayed.

Graphical and schematic view

To activate the graphical and schematic view window, click on the following symbol:



This results in the following window.

| Register | Register Name | Min | Max | Description | Value |
|----------|--------------------------------------|--------|-------|---|---------|
| 1 2001 | Modbus/Combi ID | 0 | 247 | Modbus/Combi ID | 1 |
| 2 2002 | Station ID | 1 | 65535 | Station ID | 1 |
| 3 2003 | AI - 0/20 mA or 4/20 mA | 0 | 1 | 0-20 mA or 4-20 mA | 1 |
| 4 2004 | AI - 0% scale | -30000 | 30000 | Minimum scaling (eg: 5m scaled 500) | 0 |
| 5 2005 | AI - 100% scale | -30000 | 30000 | Maximum scaling (eg: 5m scaled 500) | 500 |
| 6 2006 | AI - Start-up time in seconds | 0 | 60 | Start-up time in seconds | 5 |
| 7 2007 | AI - high limit in use | 0 | 1 | High limit in use | 0 |
| 8 2008 | AI - high limit set point | -30000 | 30000 | High limit set point (eg: 0.5m scaled 50) | 90 |
| 9 2009 | AI - high limit delay in secs. | 0 | 60000 | High limit delay in secs. | 5 |
| 10 2010 | AI - high limit alarm call | 0 | 1 | High limit alarm call | 0 |
| 11 2011 | AI - high alarm limit in use | 0 | 1 | High alarm limit in use | 0 |
| 12 2012 | AI - high alarm limit set point | -30000 | 30000 | High alarm limit set point | 0 |
| 13 2013 | AI - high alarm limit delay in secs. | 0 | 60000 | High alarm limit delay in secs. | 0 |
| 14 2014 | AI - high alarm limit alarm call | 0 | 1 | High alarm limit alarm call | 0 |
| 15 2015 | AI - low limit in use | 0 | 1 | Low limit in use | 0 |
| 16 2016 | AI - low limit set point | -30000 | 30000 | Low limit set point | 5 |
| 17 2017 | AI - low limit delay in secs. | 0 | 60000 | Low limit delay in secs. | 5 |
| 18 2018 | AI - low limit alarm call | 0 | 1 | Low limit alarm call | 0 |
| 19 2019 | AI - low alarm limit in use | 0 | 1 | Low alarm limit in use | 0 |
| 20 2020 | AI - low alarm limit set point | -30000 | 30000 | Low alarm limit set point | 0 |
| 21 2021 | AI - low alarm limit delay in secs. | 0 | 60000 | Low alarm limit delay in secs. | 0 |
| 22 2022 | AI - low alarm limit alarm call | 0 | 1 | Low alarm limit alarm call | 0 |
| 23 2023 | AI - Label | | | Signal Label | |
| 24 2033 | AI - High Limit Label | | | High Limit Label | AI HIGH |
| 25 2043 | AI - Low Limit Label | | | Low Limit Label | AI LOW |

In this menu you can get a full overview of all registers. Here you can directly edit in registers and see online values.

If you want to search for specific registers, you can use the filter function. The filter function can be applied to the register number, description and name.

If you want to see online or input values, select the tab with "online values" or "input registers".

If you want to filter, you can use the functions "start address" or "filter". If you use the start address, the desired address and the subsequent 100 registers are found. The filter function shows the specific search value. In case of changes, "reload data" is used to update the search function.

| Address | Register | Value (s16) | Value (u32) | Value |
|---------|----------|-------------|-------------|-------|
| 1 200 | 201 | | 65535 | |
| 2 201 | 202 | 4294967295 | 65535 | |
| 3 202 | 203 | | 65535 | |
| 4 203 | 204 | 4294967295 | 65535 | |
| 5 204 | 205 | | 65535 | |
| 6 205 | 206 | 4294967295 | 65535 | |
| 7 206 | 207 | 0 | 0 | |
| 8 207 | 208 | 0 | 0 | |
| 9 208 | 209 | | 65535 | |
| 10 209 | 210 | 4294967295 | 65535 | |

Applications

Pump control:



The screenshot shows the 'Regulator' interface with the 'Regulator function' dropdown set to 'Pump control'. The 'Pump Settings' tab is active, displaying various configuration options:

- Variable start level (eg: 0.5 m scale 50): 0
- Errors before pump suspension: 1
- Leak indicator timer (minutes): 0
- Interlocking enabled:
- No. of pumps: 2 Pumps (selected)
- Start level 1: 250
- Stop level 1: 20
- Delay in secs.: 0
- Start level 2: 260
- Stop level 2: 20
- Delay in secs.: 5
- Direct pumping or alternation: Direct (selected)
- Only one pump running:

In order to use SPIDER as a pump control, select "Pump control" under the "Regulator function" setting. Here you can configure the most common parameters as shown in the picture.

There are additional functions that can be selected by clicking on the corresponding tabs "Current settings", "flow interface" and "additional functions".

Current settings: Under current settings, you can choose whether you want to measure the power consumption of a pump via an associated power coil on the SPIDER or whether the power measurement comes from an energy meter or a frequency converter. In the case of energy meter or frequency converter, it requires that an Eagle HMI is fitted to the SPIDER.

Flow interface:

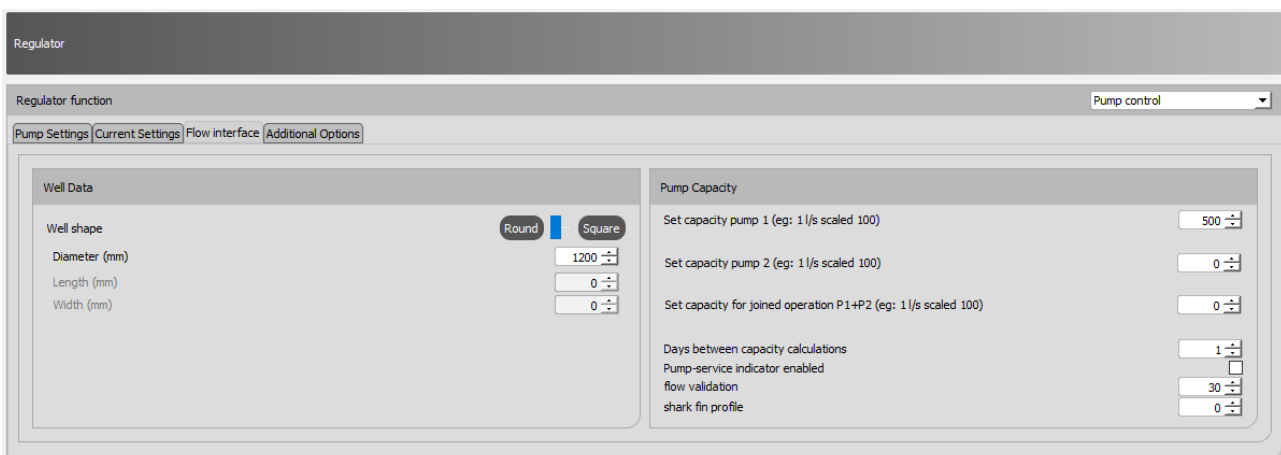

The screenshot shows the 'Regulator' interface with the 'Regulator function' dropdown set to 'Pump control'. The 'Flow interface' tab is active, displaying well and pump capacity settings:

- Well Data:**
 - Well shape: Round (selected) / Square
 - Diameter (mm): 1200
 - Length (mm): 0
 - Width (mm): 0
- Pump Capacity:**
 - Set capacity pump 1 (eg: 1 l/s scaled 100): 500
 - Set capacity pump 2 (eg: 1 l/s scaled 100): 0
 - Set capacity for joined operation P1+P2 (eg: 1 l/s scaled 100): 0
 - Days between capacity calculations: 1
 - Pump-service indicator enabled:
 - flow validation: 30
 - shark fin profile: 0

With very few settings, SPIDER can perform a validated flow calculation. You choose whether the shape of the well is round or square, then enter either diameter or the dimension of the sides in mm. This determines the surface area and SPIDER calculates on the basis of the start/stop levels how much is pumped out during a pumping cycle.

SPIDER finds the longest pump cycle for a day, calculates pump capacity and inlet time, and stores this value as the current candidate. After 5 days. The candidates are evaluated, and the SPIDER finds the most

representative values for pump capacity. This allows SPIDER to calculate the amount of pumped volume. SPIDER is also capable of calculating inlet flow which can be used to estimate the amount of non-revenue water in the system.

Additional Options:



The screenshot shows the 'Regulator' software interface with the 'Additional Options' tab selected. The interface is divided into several sections:

- Enable pump exercising:** Includes a checkbox and three input fields for 'time of day for spinning', 'Days between pump exercising', and 'Pump exercising duration', all currently set to 0.
- Daily flush enabled:** Includes a checkbox and one input field for 'Daily flush time', currently set to 0.
- Activate depth pumping:** Includes a checkbox and four input fields for 'Depth pumping - time of day (930 = 9:30 am)', 'Days between depth pumping', 'Start mode (0 = start at time, 1 = start at time + level)', and 'Depth pumping stop level (secs)', all currently set to 0.

It is possible to choose between 3 different maintenance functions.

Pump exercise: At small pumping stations, where the supply may depend on the seasons such as wells in the vacation homes, it can be helpful to get the pumps exercised at regular intervals. With SPIDER you can select this function and determine the time of day for exercise (for example Value 700 = 7:00), you can also choose how many days between the last regular pumping to the next pump exercise and you can enter the duration in seconds of exercise.

Daily emptying: It is possible to have SPIDER run an emptying function at a fixed time of day. You put a check mark in "Daily emptying on/off" and enter the desired time of day. For example, the value 915 will be perceived as the time 9:15.

Depth Pumping: SPIDER also supports depth pumping. Here you can choose the time of day for depth pumping, and the days between depth pumping.

Groundwater lowering:

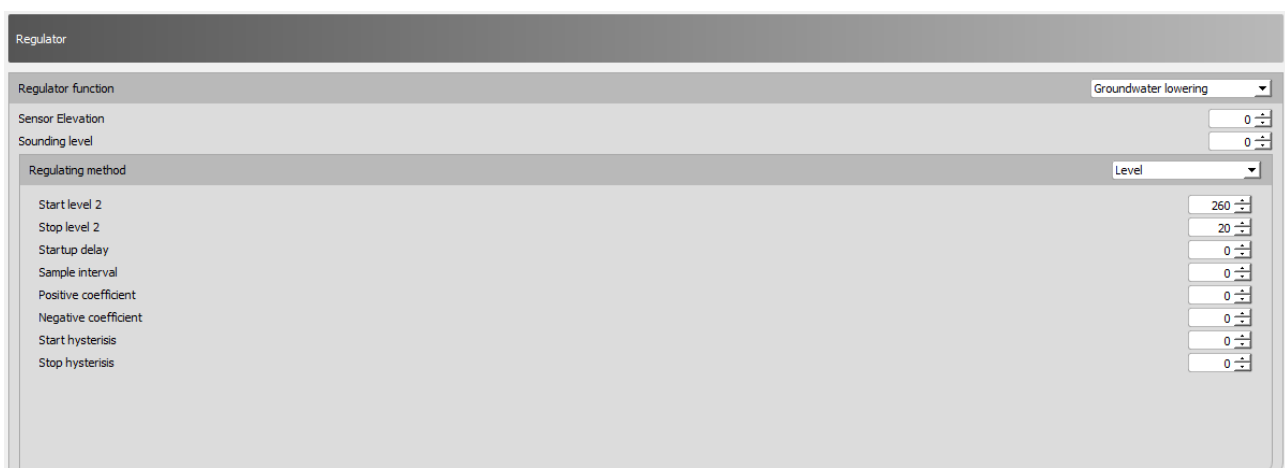

The screenshot shows the 'Regulator' software interface with the 'Groundwater lowering' function selected. The interface includes the following parameters and values:

- Sensor Elevation:** 0
- Sounding level:** 0
- Regulating method:** Level
- Start level 2:** 260
- Stop level 2:** 20
- Startup delay:** 0
- Sample interval:** 0
- Positive coefficient:** 0
- Negative coefficient:** 0
- Start hysteresis:** 0
- Stop hysteresis:** 0

By choosing ground water level the SPIDER can keep a constant water table level. Sensor elevation is the top of the sensor tube in relation to a given terrain point. In Denmark it is called "Kote DVR90". The sounding

level is the sensor depth under terrain. After putting in this data simply just pick the regulation type you wish to use.

Geni groundwater lowering: Used with Grundfos CUE converter. The SPIDER controls the CUE via GENIBus. Be aware that it is not possible to use this function together in relation to a display of any kind.

VLT groundwater lowering: Used with Danfoss converter with a ModBus communication module.

Monitoring:

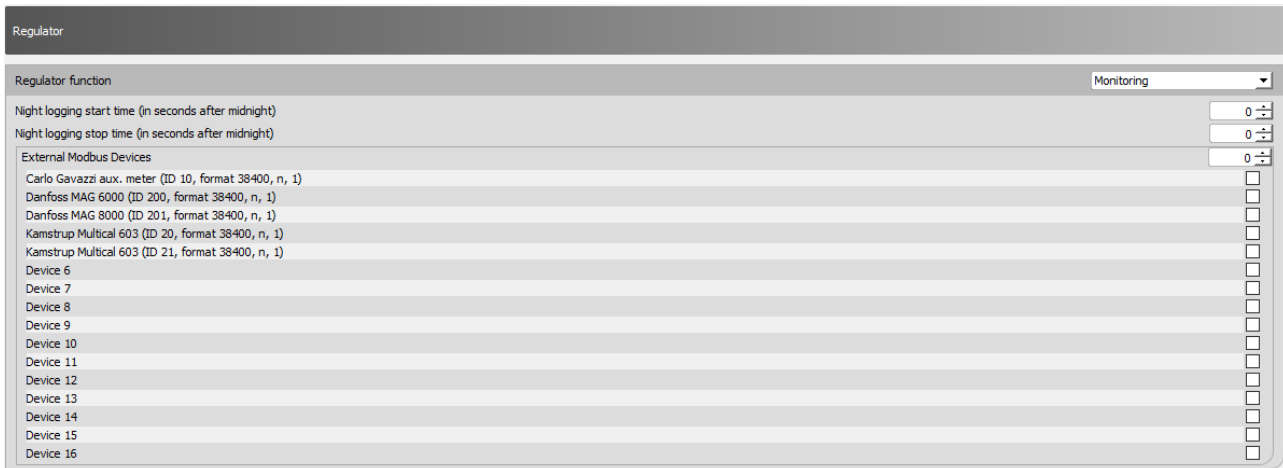

The SPIDER control can be used as a pure monitoring device and by selecting this feature, SPIDER no longer acts as pump control. It will now use ModBus communication to the selected device type installed.

Compressor control:



Concertor control:

The setup of the Concertor pumps is done through TCP/IP connection to the modules.



Concertor MASTER - (Level through APP411 module) - is to be discontinued: In this function, the Concertor module controls the pump. Start/stop is based on the values of Concertor modules and control is done completely autonomously by Concertor. It is possible to force-stop the pump, but you cannot force-start the pump. It is possible to calculate inlet flow, with precaution to the regulation from the Concertor. You can also read and write to selected Concertor registers. Ex. Set-Power (in operation read RPM, Amp, KW). You can enter "Start 1/Stop 1" levels via SPIDER/HMI. The Concertor APP411 module determines the start 2 level (+ 10cm to start 1 at maximum speed.)

For two or more pumps - If the water level increases 10 cm (4 inches) above the initial level of the first pump, then another pump starts at maximum speed. The speed is adjusted so that the inflow corresponds to the outflow. If the water level increases 4 cm (1.6 inches) more, a third pump will start and regulates in the same way as the second pump. This is also repeated for a fourth pump.

Concert Slave - (Level via SPIDER): In this function mode, the SPIDER controls the pump and performs start/stop of the pump, including the start/stop levels. The pump does not control the regulation itself, this is controlled by the SPIDER. It is not possible to write to Concertor while it is in operation. In this mode, it is possible to force stop and force start the pump. Level is entered in the SPIDER - Flow calculation (inlet + outlet) can be performed, and it is possible to read and write to selected Concertor registers. Ex. Set-Power (for operation read RPM, Amp, KW)

Other functions

High level switch version 2 (advanced function):

1. To configure high level switch version 2, first select "High level switch" under DI settings - Function selection. After this, enter the "time before starting second pump", as well as the "running time when running blind".

2. To access the "High level switch 2 function", the function selection " High level switch " must be changed to "High level switch 2".

3. In addition, there are 2 other registers to be set. To access these, select the function menu "Graphic View / Schematic View". The two registers to be changed are "time" for unchanged level measurement, and "Hysteresis" for unchanged level measurement.

| Register | Register Name | Min | Max | Description | Value |
|----------|-------------------------|--------|-------|-------------------------------------|-------|
| 1 2001 | Modbus/Combi ID | 0 | 247 | Modbus/Combi ID | 1 |
| 2 2002 | Station ID | 1 | 65535 | Station ID | 1 |
| 3 2003 | AI - 0/20 mA or 4/20 mA | 0 | 1 | 0-20 mA or 4-20 mA | 1 |
| 4 2004 | AI - 0% scale | -30000 | 30000 | Minimum scaling (eg: 5m scaled 500) | 0 |

4. Use the filter function to find registers 2785 "Time". The function shares values with "Sounding level" and must be specified in seconds, as well as 2790 "Hysteresis" which shares values with "Low flow limit" this is specified in cm.

| Register | Register Name | Min | Max | Description | Value |
|----------|-----------------------------|-----|-------|----------------|-------|
| 379 2785 | PW sensordybde under terræn | 0 | 30000 | Sounding level | 60 |
| 384 2790 | Low Flow Limit | 0 | 30000 | Low flow limit | 5 |

The hysteresis is the dead band that is around the last measured level, and if the level remains in this measuring range / dead band, for the entered time (in sec), then this is a possible high level switch situation.

If the high-water level switch is now activated, the high level switch function is triggered and the pump starts and will have an after run time, in this case 60 sec, after the level switch is deactivated.

If the level changes out of the hysteresis range, the "time" is reset and a new dead band time must occur to make control ready for a possible high level switch situation.

High level switch version 2, is an add-on function to the high level switch we use today, that way the high level switch situation is also activated, if the level meter exceeds the 4-20 mA range.

SPIDER pump control using only level switch:

Function using level switches as control for start/stop of pumps. It can be setup using the analog input setup as normal level sensor and use resistance on 4K7.

Control using one level switch for 1 pump

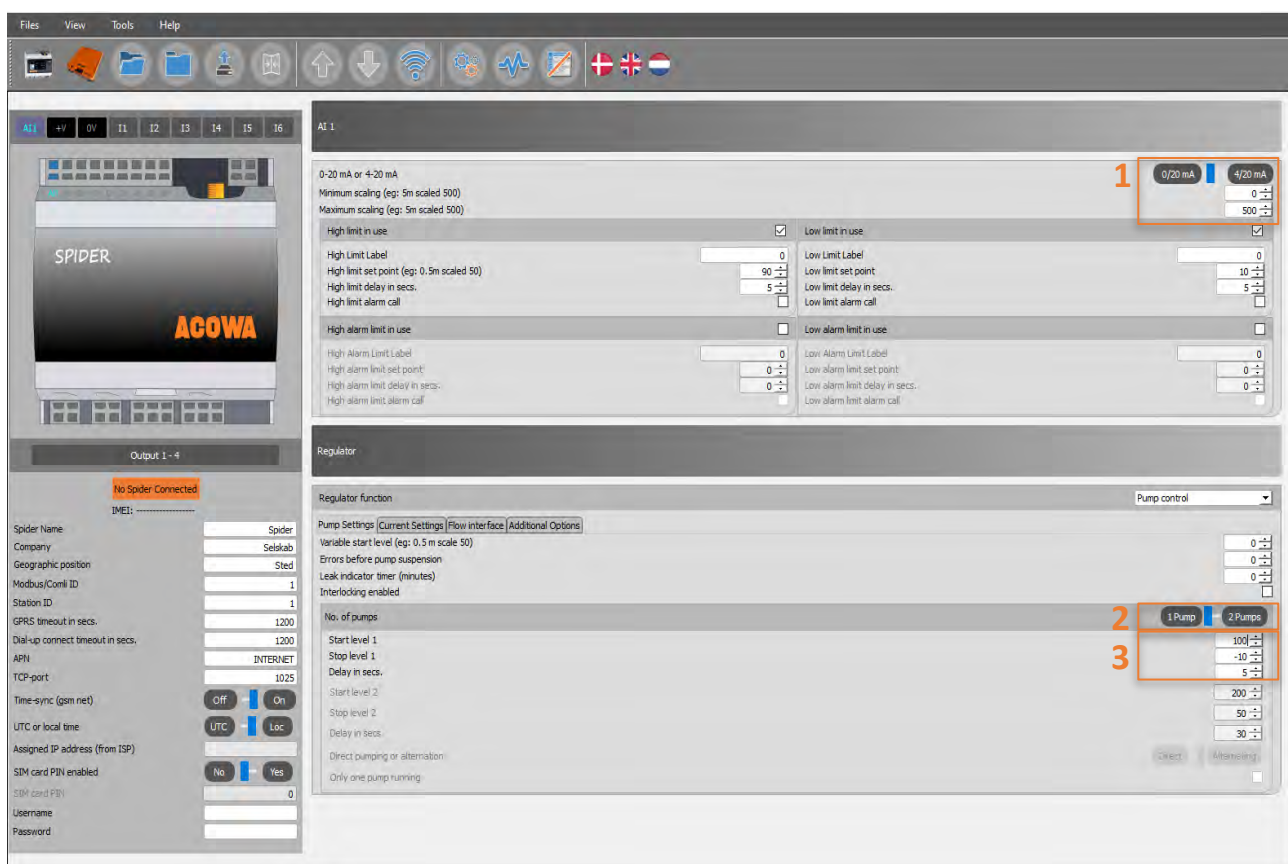

1. Choose AI 1 as 0-20 mA and range 0-500
2. Choose ONE PUMP
3. Start level 1 = 100. Stop level 1 = -10. Delay is necessary, it takes the bounces from the switch – set at 5 secs.

Setup of the Digital Output (Output 1-4)

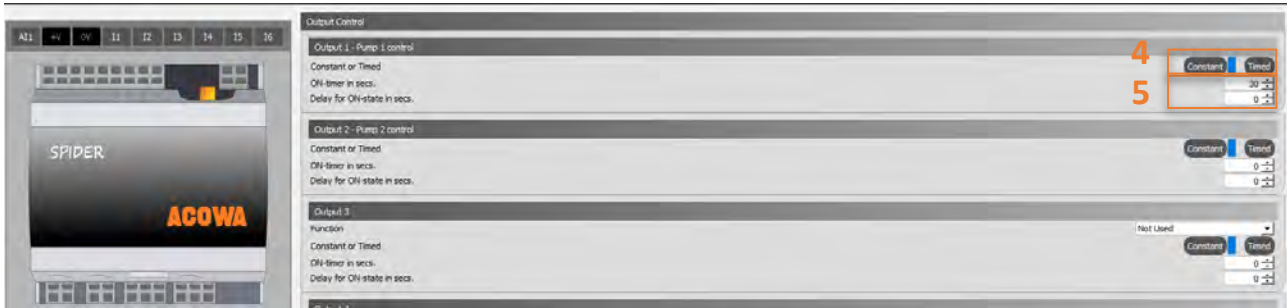

4. Output relay 1 shall be set = Time controlled
5. On-time by time controlled in seconds = 30 secs. (this is minimum running on each start).

FUNCTION: Pump 1 starts by level switch "ON" after 5 secs.
 Pump stops by level switch "OFF" minimum 30 secs.

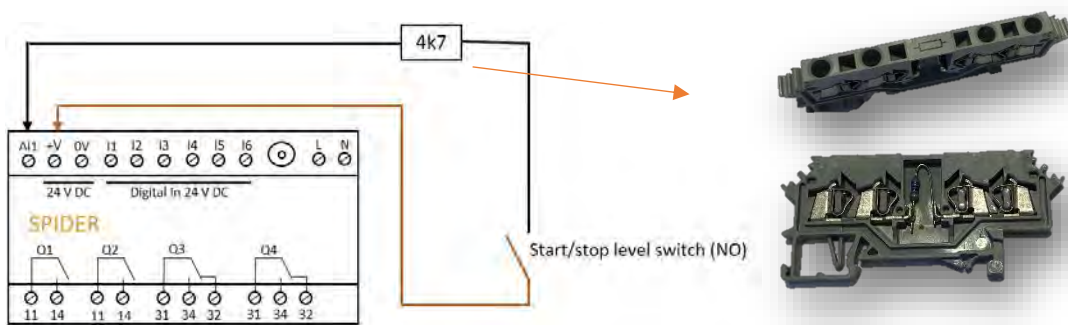

Control using two level switches for 1 pump

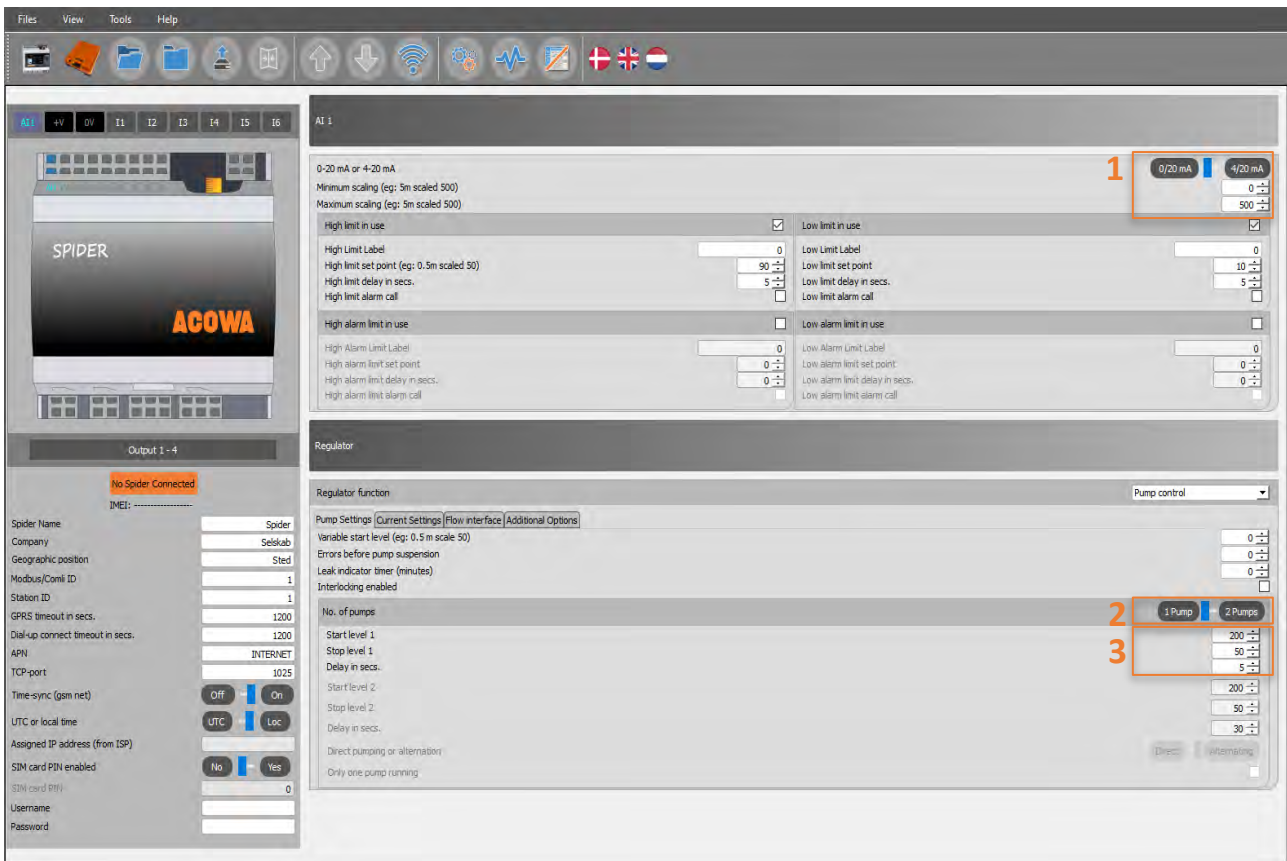

1. Choose AI 1 as 0-20 mA and range 0-500
2. Choose ONE PUMP
3. Start level 1 = 200. Stop level 1 = 50. Delay is necessary, it takes the bounces from the switch – set at 5 secs.

Setup of the Digital Output (Output 1-4)



4. Output relay 1 shall be set = Constant.

FUNCTION: Pump 1 starts by level switch "ON" after 5 sec.
Pump stops by level switch "OFF"

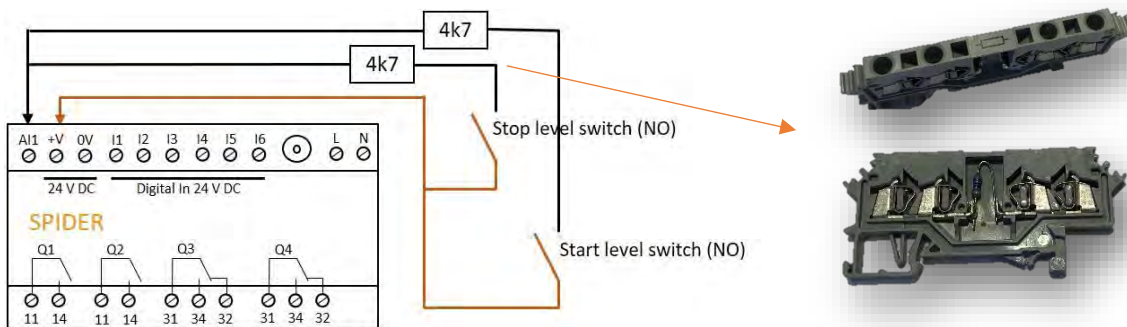

Control using two level switches for 2 pumps

The screenshot shows the ACOWA Spider control interface. The main panel is titled 'AI 1' and contains the following settings:

- 0-20 mA or 4-20 mA: 0/20 mA (selected)
- Minimum scaling (eg: 5m scaled 500): 0
- Maximum scaling (eg: 5m scaled 500): 500
- High limit in use:
- High Limit Label: 0
- High limit set point (eg: 0.5m scaled 50): 90
- High limit delay in secs.: 5
- High limit alarm call:
- Low limit in use:
- Low Limit Label: 0
- Low limit set point: 10
- Low limit delay in secs.: 5
- Low limit alarm call:
- High alarm limit in use:
- High Alarm Limit Label: 0
- High alarm limit set point: 0
- High alarm limit delay in secs.: 0
- High alarm limit alarm call:
- Low alarm limit in use:
- Low Alarm Limit Label: 0
- Low alarm limit set point: 0
- Low alarm limit delay in secs.: 0
- Low alarm limit alarm call:

The 'Regulator' section shows the following settings:

- Regulator function: Pump control
- Pump Settings (Current Settings | Flow interface | Additional Options): Pump control
- Variable start level (eg: 0.5 m scale 50): 0
- Errors before pump suspension: 0
- Leak indicator timer (minutes): 0
- Interlocking enabled:
- No. of pumps: 2 Pumps (selected)
- Start level 1: 200
- Stop level 1: 50
- Delay in secs.: 5
- Start level 2: 200
- Stop level 2: 50
- Delay in secs.: 30
- Direct pumping or alternation:
- Only one pump running:

1. Choose AI 1 as 0-20 mA and range 0-500
2. Choose TWO PUMPS
3. Start level 1 = 200. Stop level 1 = 50. Delay is necessary, it takes the bounces from the switch – set at 5 secs.
4. Start level 2 = 200. Stop level = 50. Delay before start 2 = 30 secs.

Setup of the Digital Output (Output 1-4)

The screenshot shows the 'Output Control' section of the ACOWA Spider control interface. The settings for Output 1 and Output 2 are as follows:

- Output 1 - Pump 1 control: Constant or Timed: Constant (selected)
- ON-timer in secs.: 0
- Delay for ON-state in secs.: 0
- Output 2 - Pump 2 control: Constant or Timed: Constant (selected)
- ON-timer in secs.: 0
- Delay for ON-state in secs.: 0
- Output 3: Not Used
- Output 4: Not Used

5. Output relay 1 and 2 shall be set = Constant.

FUNCTION: Pump 1 starts by level switch "ON" after 5 secs.
 Pump 2 starts by level switch "ON" after 30 secs.
 Both pumps stop by level switch "OFF"

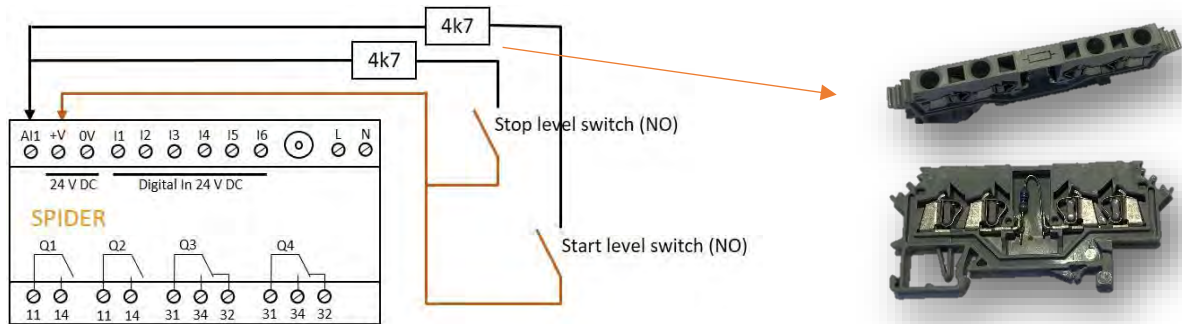

Register list "quick-guide"

| Analog | Signal | INT32 | INT32 | INT32 | INT32 | Pumping station | |
|--------|--------|--------------|----------------|------------|-----------|-----------------|--------------|
| | | Actual value | Max. yesterday | High limit | Low limit | | |
| AI 1 | Level | 20 | 192 | 22 | 24 | Phone: | |
| VI 1 | | 30 | | | | IP | |
| VI 2 | | 32 | | | | Port | |
| VI 3 | | 34 | | | | ID | |
| VI 4 | | 36 | | | | Function | Pump control |
| VI 5 | | 38 | | | | Alarm number | |
| VI 6 | | 40 | | | | | |

| Input | Signal | UINT32 | UINT32 | UINT32 | UINT32 | UINT32 | UINT32 | UINT32 |
|-----------------|------------------|--------------|-------------|--------------|------------------|------------------------------|------------------------------|----------------------------------|
| | | Status/Alarm | pulse total | pulses today | pulses yesterday | Operating time total (secs.) | Operating time today (secs.) | Operating time yesterday (secs.) |
| DI 1 | I/O | 4:0 | 500 | 600 | 700 | 550 | 650 | 750 |
| DI 2 | I/O | 4:1 | 502 | 602 | 702 | 552 | 652 | 752 |
| DI 3 | Disp. | 4:2 | 504 | 604 | 704 | 554 | 654 | 754 |
| DI 4 | Disp. | 4:3 | 506 | 606 | 706 | 556 | 656 | 756 |
| DI 5 | Water on floor | 4:4 | 508 | 608 | 708 | 558 | 658 | 758 |
| DI 6 | Opt. Rain gauge | 4:5 | 510 | 610 | 710 | 560 | 660 | 760 |
| DI 7 (IO DI 1) | Thermal error P1 | 4:6 | 528 | 628 | 728 | 578 | 678 | 778 |
| DI 8 (IO DI 2) | Klixon P1 | 4:7 | 530 | 630 | 730 | 580 | 680 | 780 |
| DI 9 (IO DI 3) | Manual P1 | 4:8 | 532 | 632 | 732 | 582 | 682 | 782 |
| DI 10 (IO DI 4) | Transient error | 4:9 | 534 | 634 | 734 | 584 | 684 | 784 |
| DI 11 (IO DI 5) | Thermal error P2 | 4:10 | 536 | 636 | 736 | 586 | 686 | 786 |
| DI 12 (IO DI 6) | Klixon 2 | 4:11 | 538 | 638 | 738 | 588 | 688 | 788 |
| DI 13 (IO DI 7) | Manual P2 | 4:12 | 540 | 640 | 740 | 590 | 690 | 790 |
| DI 14 (IO DI 8) | High water level | 4:13 | 542 | 642 | 742 | 592 | 692 | 792 |
| Description | | | | | | <i>(Seconds)</i> | <i>(Seconds)</i> | <i>(Seconds)</i> |

| Output | Signal | UINT32 | UINT32 | UINT32 | UINT32 | UINT32 | UINT32 | UINT32 |
|-------------|--------|----------------|-------------|--------------|------------------|------------------------------|------------------------------|----------------------------------|
| | | Status/Command | pulse total | pulses today | pulses yesterday | Operating time total (secs.) | Operating time today (secs.) | Operating time yesterday (secs.) |
| DO 1 | Pump 1 | 2:0 | 800 | 900 | 1000 | 850 | 950 | 1050 |
| DO 2 | Pump 2 | 2:1 | 802 | 902 | 1002 | 852 | 952 | 1052 |
| DO 3 | | 2:3 | 804 | 904 | 1004 | 854 | 954 | 1054 |
| DO 4 | | 2:4 | 806 | 906 | 1006 | 856 | 956 | 1056 |
| Description | | | | | | <i>(Seconds)</i> | <i>(Seconds)</i> | <i>(Seconds)</i> |

| Pump control | Signal | UINT32 | UINT32 | UINT32 | UINT32 | UINT32 | UINT32 | UINT32 |
|--------------|--------|-------------------------------------|-------------|--------------|------------------|------------------------------|------------------------------|----------------------------------|
| | | Status/Command | pulse total | pulses today | pulses yesterday | Operating time total (secs.) | Operating time today (secs.) | Operating time yesterday (secs.) |
| Pump 1 | Pump 1 | 70 | 100 | 128 | 156 | 108 | 136 | 164 |
| Pump 2 | Pump 2 | 72 | 102 | 130 | 158 | 110 | 138 | 166 |
| Description | | <i>See section "pump word list"</i> | | | | <i>(Seconds)</i> | <i>(Seconds)</i> | <i>(Seconds)</i> |

| p control | UINT32 | UINT32 | UINT32 | UINT32 | UINT32 | UINT32 | UINT32 | UINT32 | UINT32 |
|---------------------|---|--|-----------------------|--|--|--|---|---|---|
| | Current | Min. current | Latest operating time | Latest capacity | Outlet flow | Inlet flow | Total quantity | Quantity today | Quantity yesterday |
| Pump 1 | 26 | 44 | 64 | 58 | | | 116 | 144 | 172 |
| Pump 2 | 28 | 48 | 66 | 60 | | | 118 | 146 | 174 |
| Both pumps together | | | 68 | 62 | | | 120 | 148 | 176 |
| Station | | | | | 78 | 226 | 122 | 150 | 178 |
| Description | Current from energy meter, coil or CUE (Amps with 1 decimal) | Low current limit (Amps with 1 decimal) "If min. current is not exceeded, start failure occurs after 60 sec" | (Seconds) | Calculated capacity (L/s with 2 decimals) | Calculated flow (L/s with 2 decimals) | Calculated flow (L/s with 2 decimals) | Calculated quantity (m ³ with 2 decimals) | Calculated quantity (m ³ with 2 decimals) | Calculated quantity (m ³ with 2 decimals) |

| Pump control | Signal | UINT32 |
|----------------|----------|-----------|
| | | Setpoints |
| Start level 1 | 1. start | 50 |
| Start level 2. | 2. start | 52 |
| Stop level 1. | 1. stop | 54 |
| Stop level 2. | 2. stop | 56 |

| External gauges | UINT32 | UINT32 | UINT32 |
|-----------------|--|--|--|
| | Total | Today | Yesterday |
| Flow gauge | 250 | 252 | 254 |
| Description | Flow pulse (m ³ with 2 decimals) If a pulse input is used, it needs to be in the same resolution as the pulse | Flow pulse (m ³ with 2 decimals) If a pulse input is used, it needs to be in the same resolution as the pulse | Flow pulse (m ³ with 2 decimals) If a pulse input is used, it needs to be in the same resolution as the pulse |
| Energy meter | 238 | 240 | 242 |
| Description | (kW with 1 decimal) | (kW with 1 decimal) | (kW with 1 decimal) |
| Rain gauge | 256 | 258 | 260 |
| Description | (0,2 mm per pulse with 1 decimal) | (0,2 mm per pulse with 1 decimal) | (0,2 mm per pulse with 1 decimal) |

| Converters | UINT16 | UINT16 | UINT16 | UINT16 |
|-------------|-----------------------|---------------------|---------------------|---------------------|
| | CUE Amp. | CUE Hz | CUE kW | CUE ref |
| | 1853 | 1852 | 1851 | 1850 |
| | 1803 | 1802 | 1801 | 1800 |
| Description | (Amps with 1 decimal) | (Hz with 1 decimal) | (kW with 2 decimal) | (Hz with 1 decimal) |

| Pump word: P1=Register 70 P2=Register 72 | Warning | Alarm |
|---|---------|----------------|
| Bit 0: Pump started | Running | Running |
| Bit 1: Pump error - Therma | | Thermal error |
| Bit 2: Pump error - Klixon | | Klixon error |
| Bit 3: Pump - manual mode | | Manual mode |
| Bit 4: Pump error - operation signal not received | | Starting error |

| Pump word: P1=Register 70 P2=Register 72 | Warning | Alarm |
|--|----------------------|---------------------------|
| Bit 5: Pump warning - Low flow | Low flow | |
| Bit 6: Pump warning - long operation time (Time > total time / (total starts x 1,5)) | Long operation time | |
| Bit 7: Internal | | |
| Bit 8: Internal | | |
| Bit 9: Pump error - High level switch | | Error + High level switch |
| Bit 10: Pump error - High level | | Error + High level |
| Bit 11: Pump - started by high level switch | Operation by switch | |
| Bit 12: Pump - Back stopped | Back-stop controlled | Error ModBus |
| Bit 13: Pump error - repeatedly (needs to be reset) | | Suspended |
| Bit 14: Pump - Manual mode | | Locally operated |
| Bit 15: Pump - Forced to stop by either panel or SRO | Forced to stop | |
| Bit 16: Pump - Manual mode by SRO | Manually | |
| Bit 17: Pump - started manually by SRO (Requires bit 16 = 1) | Run manually | |
| Bit 18: Stop - manual mode | Stop Manually | |

| Time / Date | UINT32 |
|-------------|--------|
| Seconds | 80 |
| Minutes | 82 |
| Hour | 84 |
| Day | 86 |
| Month | 88 |
| Year | 90 |

| System information | UINT32 |
|--------------------|--------------------------------|
| Id number | 0 |
| GSM-signal | 94 |
| Description | <i>0-100% (0 decimals)</i> |

| SPIDER status: Register 92 | Status | Warning | Alarm |
|---|--------|---------|-------|
| Bit 0: Emergency control active | √ | | |
| Bit 1: Emergence control active 2 pumps | √ | | |
| Bit 2: Internal power supply failure | | | √ |
| Bit 3: P1+P2 in error | | | √ |
| Bit 4: P1 in error plus high level | | | √ |
| Bit 5: P2 in error plus high level | | | √ |
| Bit 6: External power supply failure | | | √ |
| Bit 7: Transmitter error | | | √ |
| Bit 8: One pump in operation | √ | | |
| Bit 9: Both pumps in operation | √ | | |
| Bit 10: Number of pumps controlled (0=1, 1=2) | √ | | |
| Bit 11: Control in alarm | | | √ |
| Bit 12: Warning leakage | | √ | |
| Bit 13: P1 capacity needs update | | √ | |
| Bit 14: P2 capacity needs update | | √ | |
| Bit 15: Co-operation capacity needs update | | √ | |
| Bit 16: IO-external error DI1-4 | | √ | |
| Bit 17: IO-external error DI5-8 | | √ | |
| Bit 18: Waiting for co-operation | | √ | |

| SPIDER status: Register 92 | Status | Warning | Alarm |
|-------------------------------------|--------|---------|-------|
| Bit 19: Back-stop control all pumps | √ | | |
| Bit 20: Back-stop control P1 | √ | | |
| Bit 21: Back-stop control P2 | √ | | |
| Bit 22: Communication error CUE P1 | | √ | |
| Bit 23: Communication error CUE P2 | | √ | |
| Bit 24: Communication error HMI | | √ | |
| Bit 25: Waiting for depth pumping | √ | | |
| Bit 26: High level switch | | | √ |

| | | | | |
|-----|----------------------------------|--------|---|---------------------------------------|
| 310 | Energy meter - V L1-N | UINT32 | R | Voltage phase 1 (1 decimal) |
| 312 | Energy meter - V L2-N | UINT32 | R | Voltage phase 2 (1 decimal) |
| 314 | Energy meter - V L3-N | UINT32 | R | Voltage phase 3 (1 decimal) |
| 316 | Energy meter - V L1-L2 | UINT32 | R | Voltage between phase 1-2 (1 decimal) |
| 318 | Energy meter - V L2-L3 | UINT32 | R | Voltage between phase 2-3 (1 decimal) |
| 320 | Energy meter - V L3-L1 | UINT32 | R | Voltage between phase 3-1 (1 decimal) |
| 322 | Energy meter - A L1 | UINT32 | R | Current phase 1 (3 decimals) |
| 324 | Energy meter - A L2 | UINT32 | R | Current phase 2 (3 decimals) |
| 326 | Energy meter - A L3 | UINT32 | R | Current phase 3 (3 decimals) |
| 328 | Energy meter - W L1 | UINT32 | R | Power kW phase1 (1 decimal) |
| 330 | Energy meter - W L2 | UINT32 | R | Power kW phase 2 (1 decimal) |
| 332 | Energy meter - W L3 | UINT32 | R | Power kW phase 3 (1 decimal) |
| 334 | Energy meter - VA L1 | UINT32 | R | |
| 336 | Energy meter - VA L2 | UINT32 | R | |
| 338 | Energy meter - VA L3 | UINT32 | R | |
| 340 | Energy meter - VAR L1 | UINT32 | R | |
| 342 | Energy meter - VAR L2 | UINT32 | R | |
| 344 | Energy meter - VAR L3 | UINT32 | R | |
| 346 | Energy meter - V L-N Σ | UINT32 | R | |
| 348 | Energy meter - V L-L Σ | UINT32 | R | |
| 350 | Energy meter - W Σ | UINT32 | R | Power kW total (1 decimal) |
| 352 | Energy meter - VA Σ | UINT32 | R | |
| 354 | Energy meter - VAR Σ | UINT32 | R | |
| 356 | Energy meter - PF L1 | UINT16 | R | Cos Phi phase 1 (3 decimals) |
| 357 | Energy meter - PF L2 | UINT16 | R | Cos Phi phase 2 (3 decimals) |
| 358 | Energy meter - PF L3 | UINT16 | R | Cos Phi phase 3 (3 decimals) |
| 359 | Energy meter - PF Σ | UINT16 | R | Cos Phi all phases (3 decimals) |
| 360 | Energy meter - Phase Sequence | UINT16 | R | |
| 361 | Energy meter - Hz | UINT16 | R | |
| 362 | Energy meter - kWh (+) TOT | UINT32 | R | kWh total counter |
| 364 | Energy meter - kvarh(+) TOT | UINT32 | R | |
| 366 | Energy meter - kWdmd | UINT32 | R | |
| 368 | Energy meter - kWdmd peak | UINT32 | R | |
| 370 | Energy meter - kWh (+) Partial | UINT32 | R | |
| 372 | Energy meter - kvarh (+) Partial | UINT32 | R | |
| 374 | Energy meter - kwh (+) L1 | UINT32 | R | kWh counter phase 1 (1 deccimal) |
| 376 | Energy meter - kwh (+) L2 | UINT32 | R | kWh counter phase 2 (1 decimal) |
| 378 | Energy meter - kwh (+) L3 | UINT32 | R | kWh counter phase 3 (1 decimal) |



Future safe Instrumentation

The mission of ACOWA Instruments is to deliver quality products for instrumentation, based on newest available technology and equipped with advanced, thoroughly tested functionality. Choosing an ACOWA products means choosing a future safe product.

High Speed development

If you choose ACOWA Instruments, you choose a future-proof product.

Our skilled developers constantly have a finger on the pulse and make sure that all products labelled ACOWA Instruments, are amongst the best on the market.

Danish design - from top to bottom

ACOWA products are produced and developed in Denmark. This goes for hardware as well as software. On top of this, all development takes place in close dialogue with our customers.

rights © All Rights Reserved ACOWA Instruments 2020

ACOWA INSTRUMENTS INDUSTRIVEJ 10,
8305 SAMSE Phone.: +45 72 21 79 79
INFO@ACOWA.DK · WWW.ACOWA.DK

ACOWA
INSTRUMENTS